

KNOW THE GAME

# Sailing

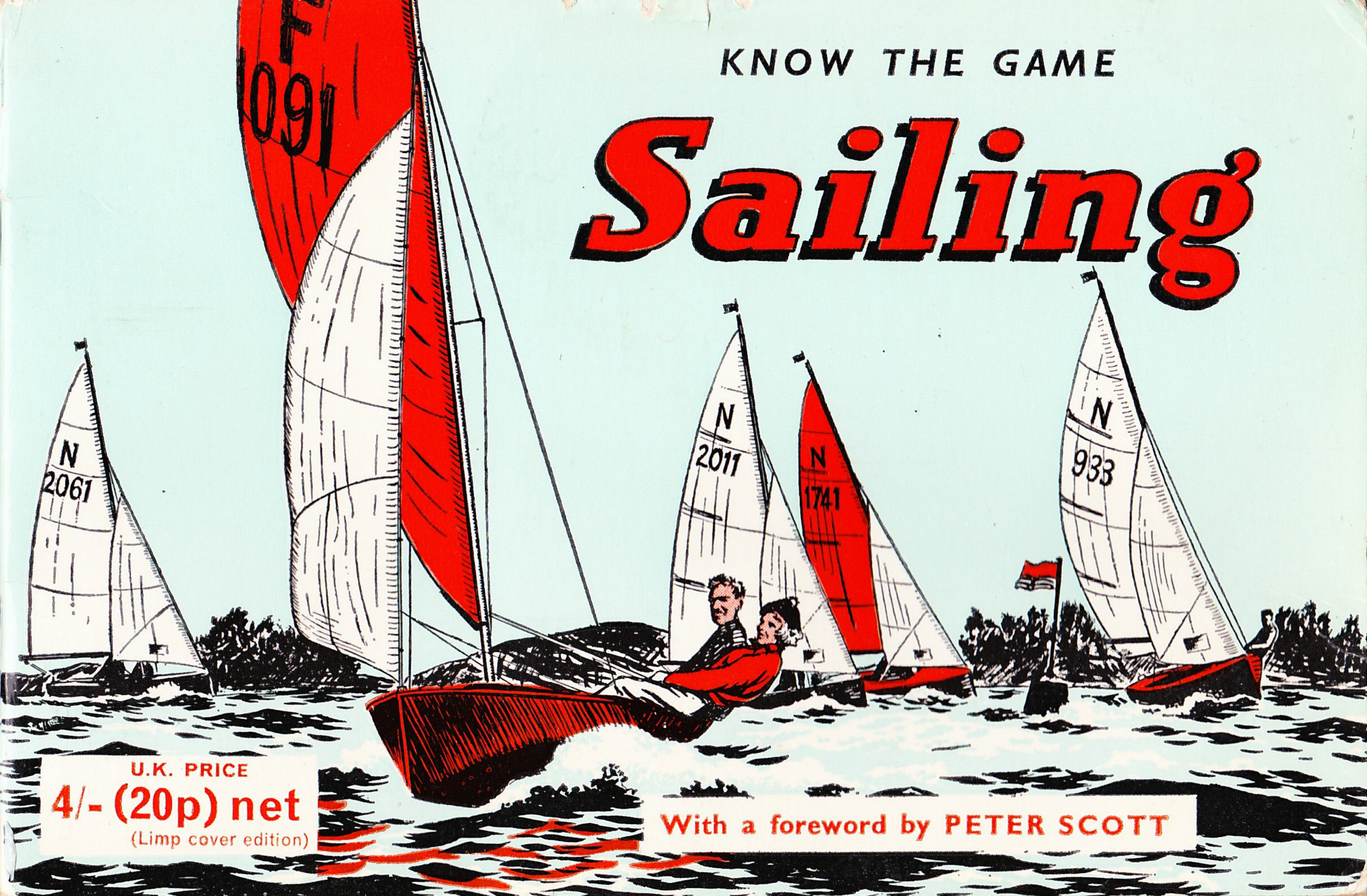

U.K. PRICE  
**4/- (20p) net**  
(Limp cover edition)

With a foreword by **PETER SCOTT**

3 Southwold Road  
BEXLEY  
Kent  
DA5 1LZ



*always out in front*

**MARLOW**

---

**YACHT ROPES**

in TERYLENE • NYLON • ULSTRON • COURLENE

---

● FROM

YOUR

CHANDLER

**MARLOW ROPES LIMITED**

Marlow House • Lloyds Avenue • London E.C.3  
Tel. ROYal 6044 (6 lines)

*The Synthetic  
Ropemaking division  
of Hawkins & Tipson Ltd*

' Know the Game ' Series

# SAILING

## FOREWORD

When you pick up this book it shows you are interested in sailing; indeed you should be for these islands have been known for centuries as a good breeding ground of sailors.

There must be nearly a quarter of a million people in Britain who sail for pleasure and the sport is growing all the time. More and more people are able to buy boats which will give them healthy enjoyment in their leisure hours.

Sailing brings people closer to nature and is an excellent form of character training. There are always new things to learn so that it can never become a dull routine. It is a sport which has a great future, particularly with dinghies, for it is in these that most of the young today learn to develop their knowledge and skill.

Here is a carefully compiled booklet that gives, in an easily understandable way, many details of sailing in small dinghies, showing the essentials with few words and many pictures.

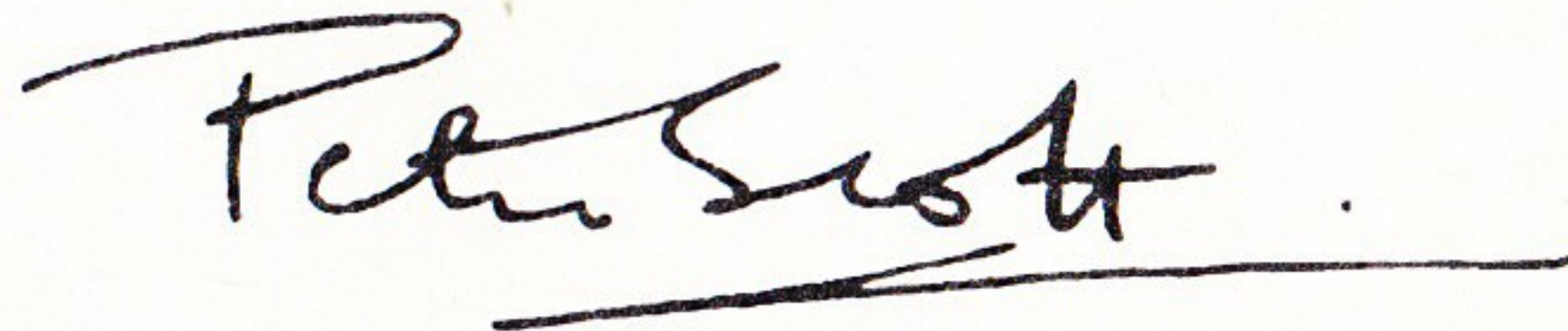

PETER SCOTT

## CONTENTS

The boat and its fittings	..	..	..	..	2
Choosing a boat	..	..	..	..	4
Buoyancy and bailers	..	..	..	..	8
The Rigging	..	..	..	..	9
Hoisting the sails	..	..	..	..	10
Reefing a sail	..	..	..	..	12
The wind	..	..	..	..	13
Balance and trim	..	..	..	..	15
Getting under way	..	..	..	..	17
Sailing the boat	..	..	..	..	19
Capsize Drill	..	..	..	..	25
Knots and hitches	..	..	..	..	27
Maintenance	..	..	..	..	28
Some Racing Rules	..	..	..	..	29
Beaufort Wind Scale	..	..	..	..	35
The Royal Yachting Association	..	..	..	..	36
Sailing terms	..	..	..	..	37

# The Boat and its Fittings

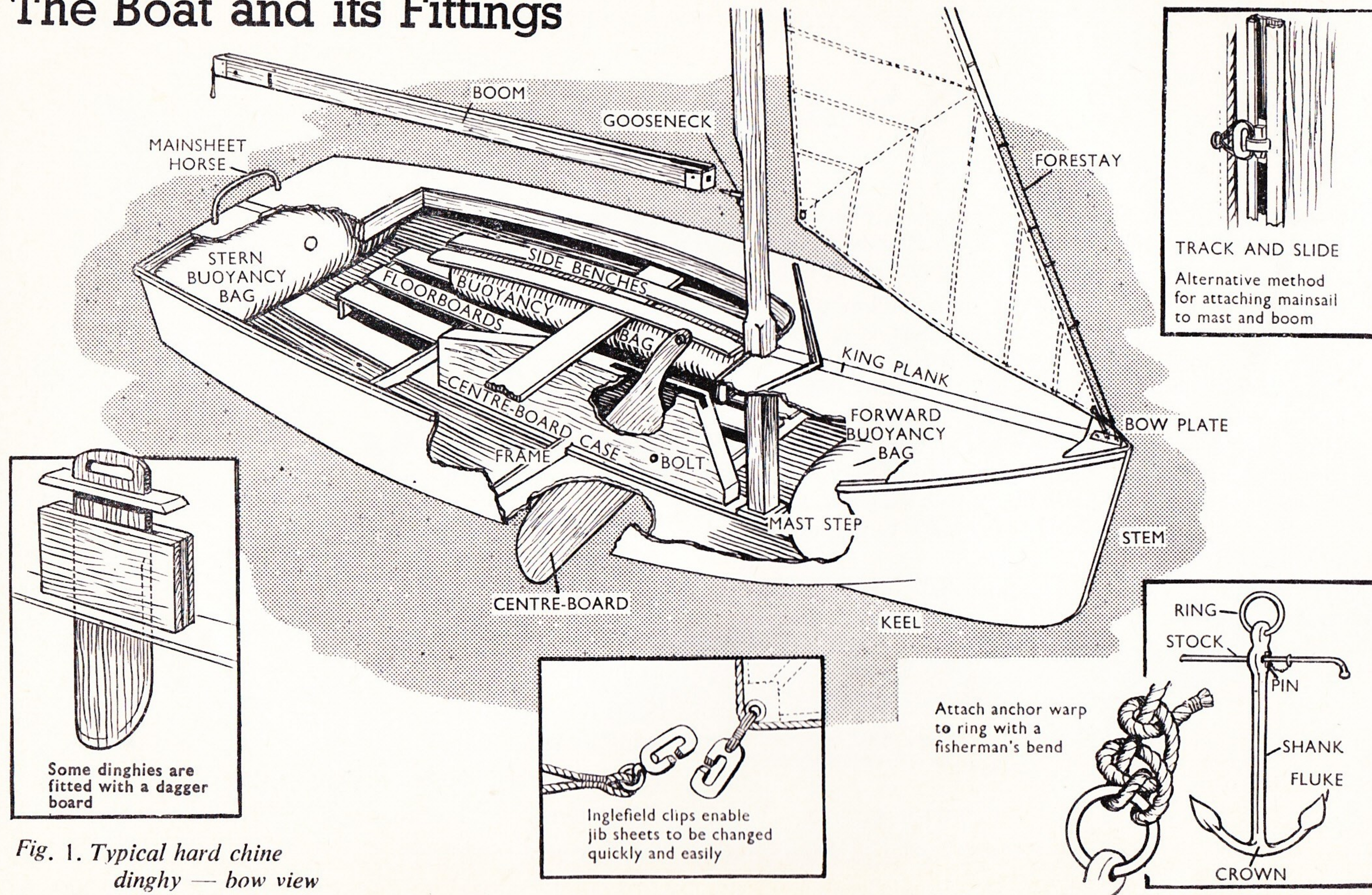
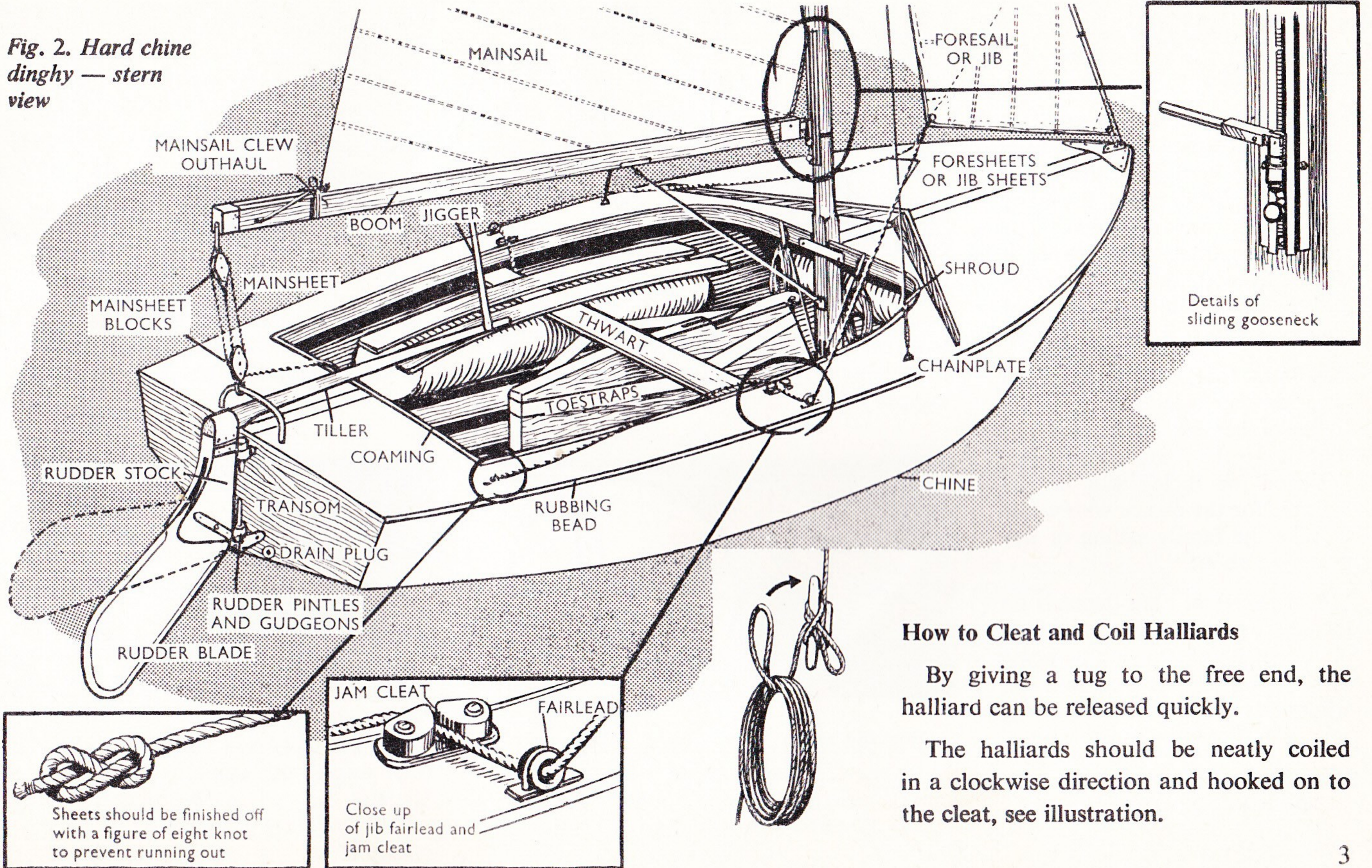

Fig. 1. Typical hard chine dinghy — bow view

**Fig. 2. Hard chine dinghy — stern view**



**How to Cleat and Coil Halliards**

By giving a tug to the free end, the halliard can be released quickly.

The halliards should be neatly coiled in a clockwise direction and hooked on to the cleat, see illustration.

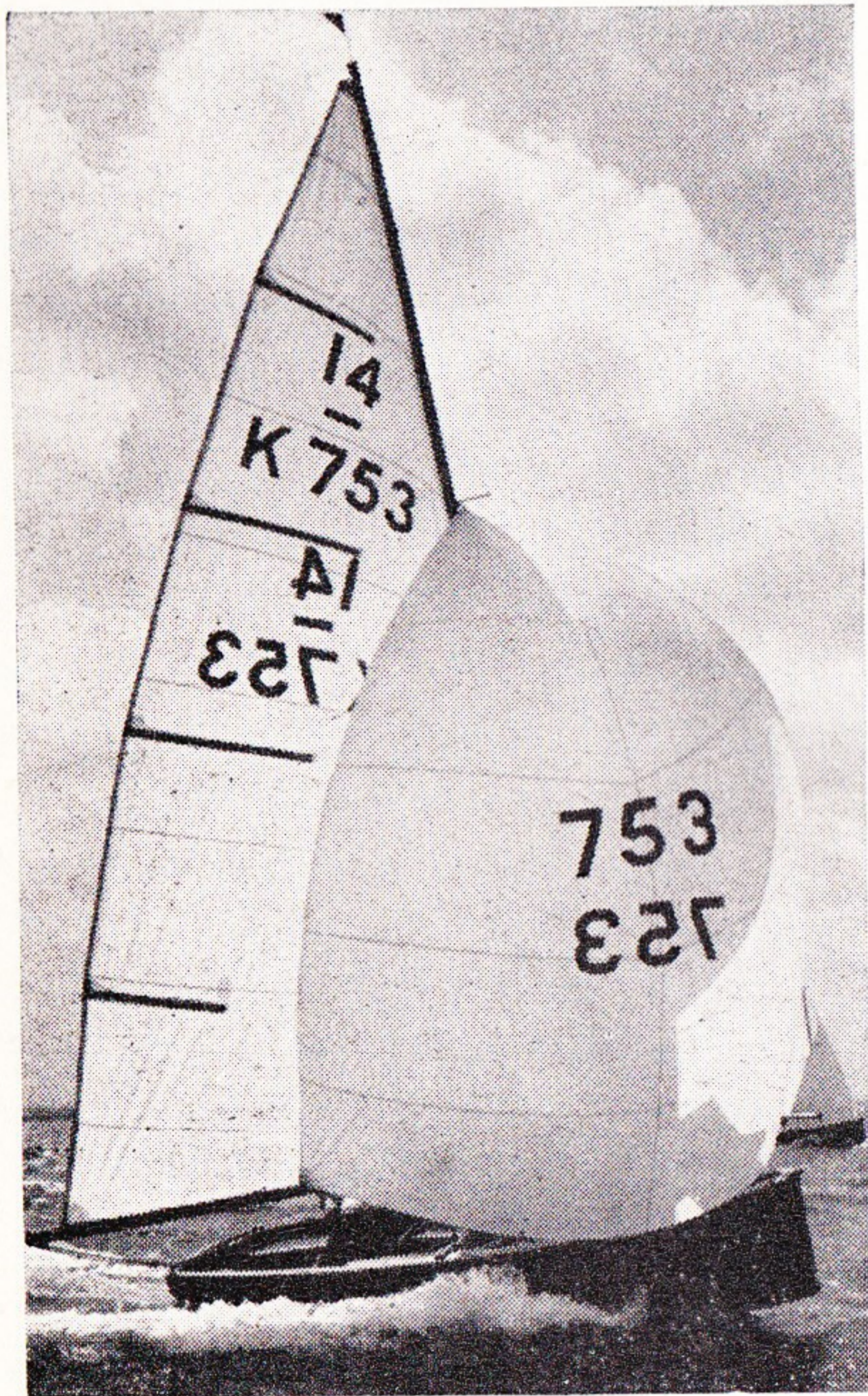

Photo: Eileen Ramsay

*Fig. 8. This International 14 Foot Dinghy is travelling fast on the 'reach' with her spinnaker drawing. She is a finely developed example of a long established class.*

### 'Restricted Classes'

The International 14, the National 12 ft. and Merlin Rocket are examples of well established restricted classes.

The measurement rules of the restricted (or development) classes allow for a variety of design of hull and rigging in each class. Fresh designs are added each year as designers search for a little more speed, improve existing plans and try out new materials and ideas.

This may mean that older craft are outclassed gradually but the measurement rules are framed so that the overnight changes never occur to make one boat faster than all the others in the class.

Restricted class boats are generally pure racing craft and although they appeal principally to the owner interested in tuning and development, many are sailed exactly as collected from the builder. These boats provide fast and exciting sailing, but they need careful handling. Beginners should have expert tuition.



Photo: Eileen Ramsay

*Fig. 9.*

*National 12 ft. dinghies are highly developed racing craft. Originally designed to be 'popular' alternatives to the International 14ft., they were soon well established in their own right.*

*Competition between International 14 ft. sailors first stimulated dinghy building and racing in Britain. The 14's and 12's always attract expert designers and crews.*



*Fig. 10. National Firefly running before the wind*



Photo: Eileen Ramsay

*Fig. 11. National Enterprise showing chines at the bow*



*Fig. 12. Mirror Dinghy on a broad reach*

### **'One Designs'**

The one design classes include the National Firefly and National Enterprise which are very different in design but widely established.

Each boat is built to the same 'one' design originally specified in its class rules and this ensures that all the boats in the class are exactly alike. Some minor details are left

free so that the owner can site his fairleads and toe straps etc., to suit himself and his crew. Older craft are not readily outclassed, although they may require new suits of sails, and they maintain their value for a long period.

Many of the one designs which provide very keen racing may also be used for family day-sailing, are safe for children and stable enough for beginners.

# Buoyancy and Bailers

All modern dinghies have reserve buoyancy designed to support the crew and allow the boat to be bailed out offshore after a capsize. Some boats have built in buoyancy tanks, but many rely on strong PVC or canvas air bags. The diagram opposite shows a typical layout.

These bags are securely fastened to the boat by wide canvas or Terylene straps held in place by screwed plates. Each year the buoyancy arrangements of a racing dinghy must pass a test before the boat is allowed to compete.

## Self Bailers

Self bailers are fitted to many modern dinghies. They are fitted through the bottom of the hull and are designed to operate by suction at quite low speeds. Care must be taken with some types to retract them before coming ashore.

A dry boat makes a lively boat. Never allow water to collect because it will act as moving ballast and upset the boat's sailing qualities. Its weight will also make the boat sluggish.

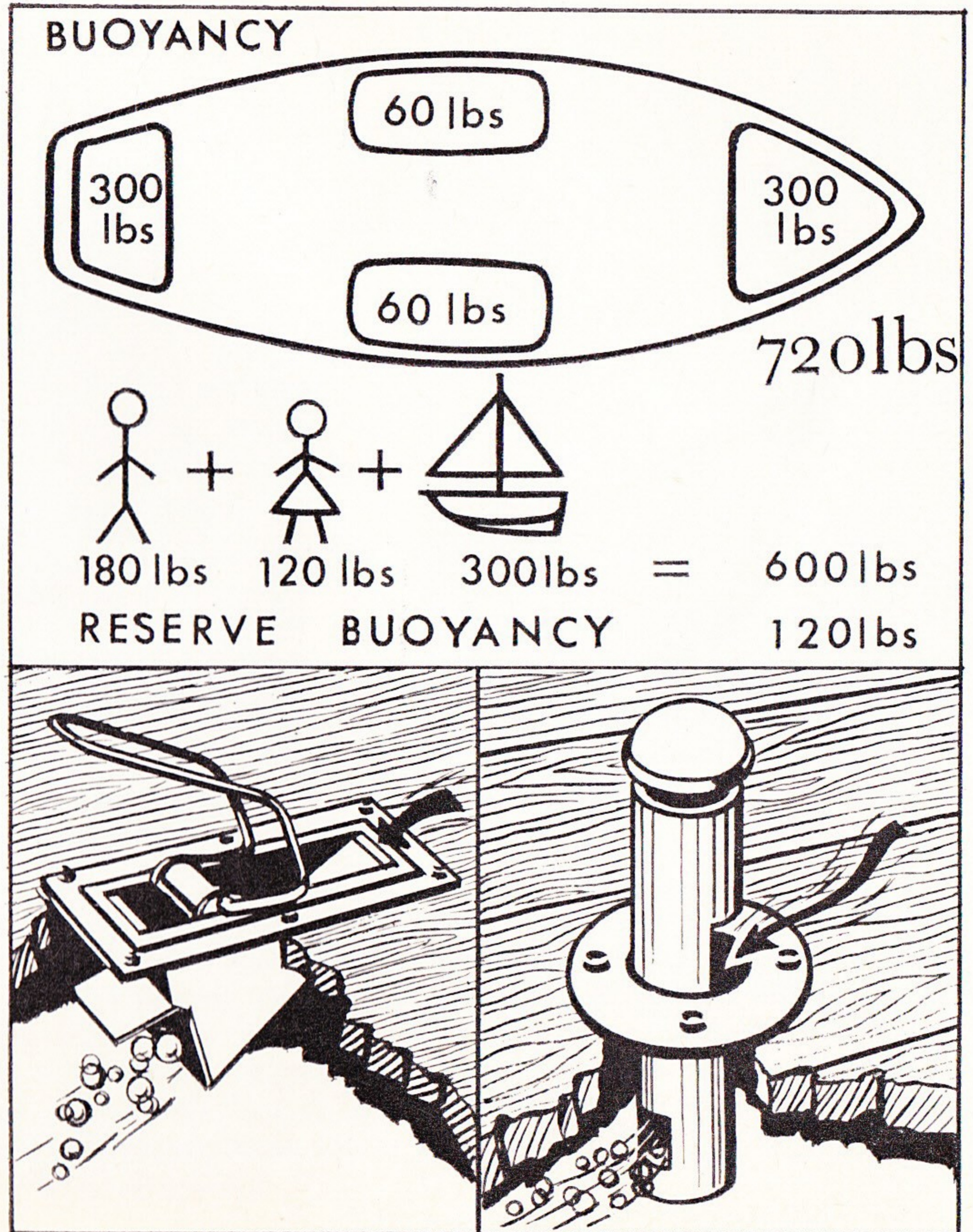

# The Rigging

*Standing Rigging* (Fig. 15). Supports the mast, is always of wire and consists of:—

A *forestay* (F) which is shackled to a fitting on the stem head.

A pair of side stays (ss) (*shrouds*) are secured to the chain plates with adjustable rigging screws or lanyards (see Fig. 15A). Rigging screws are better than rope lanyards but should be well-lubricated to prevent rust, and wired (see Fig. 15B) to remove risk of them unscrewing while under way. The stability of the sail plan depends on their correct adjustment.

Spreaders (s), are additional supports attached to the mast.

*Running Rigging* (Fig. 16). The ropes (*halyards*) used to hoist the sails and burgee, are usually of flexible steel, with hemp lanyards or pre-stretched synthetic rope.

The ropes (*sheets*) used to control the sails, are usually of braided cotton or terylene. They should remain soft when wet. Synthetic rope is expensive but very strong, durable and well worth the extra money.

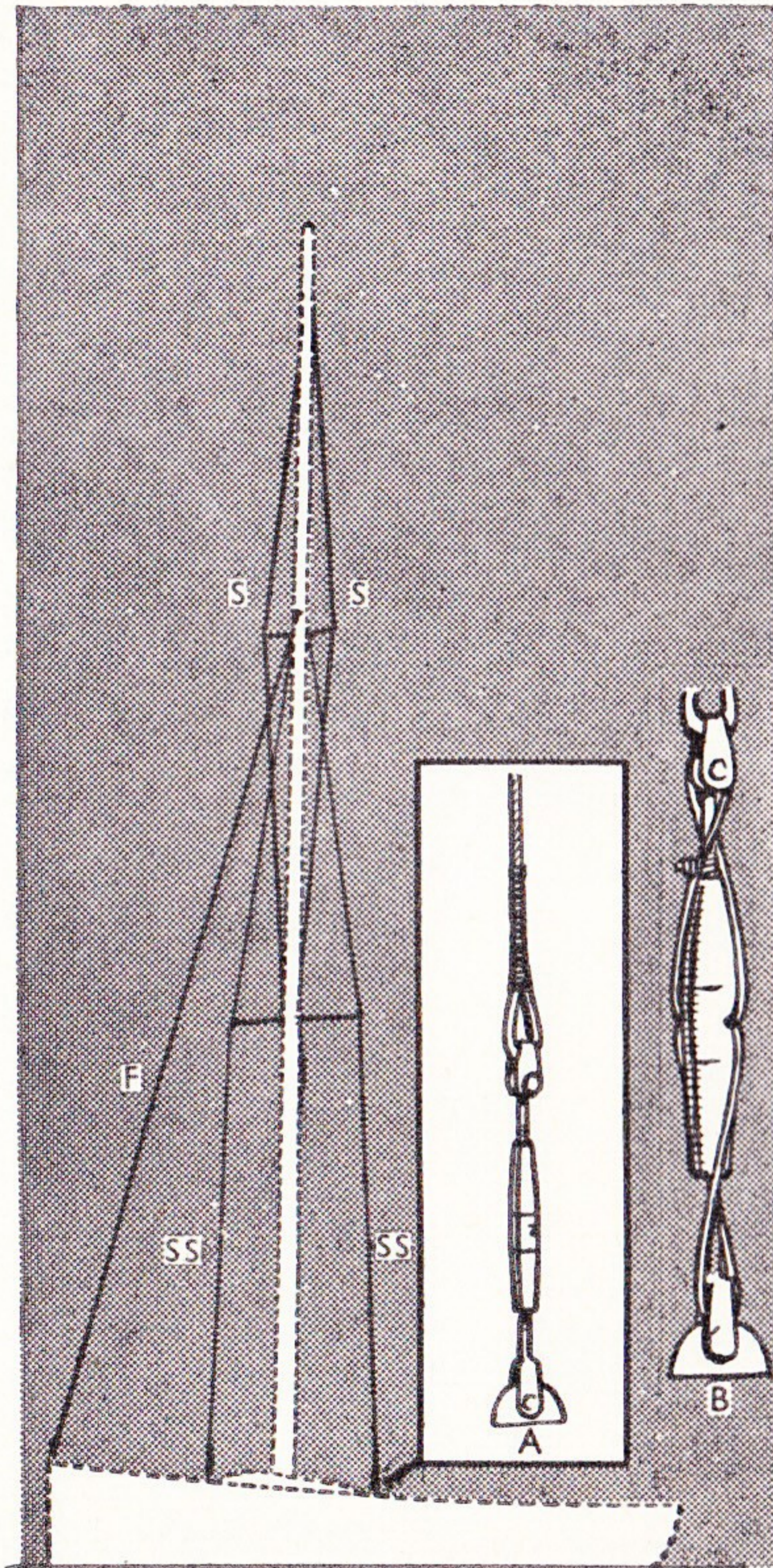

Fig. 15. Standing rigging

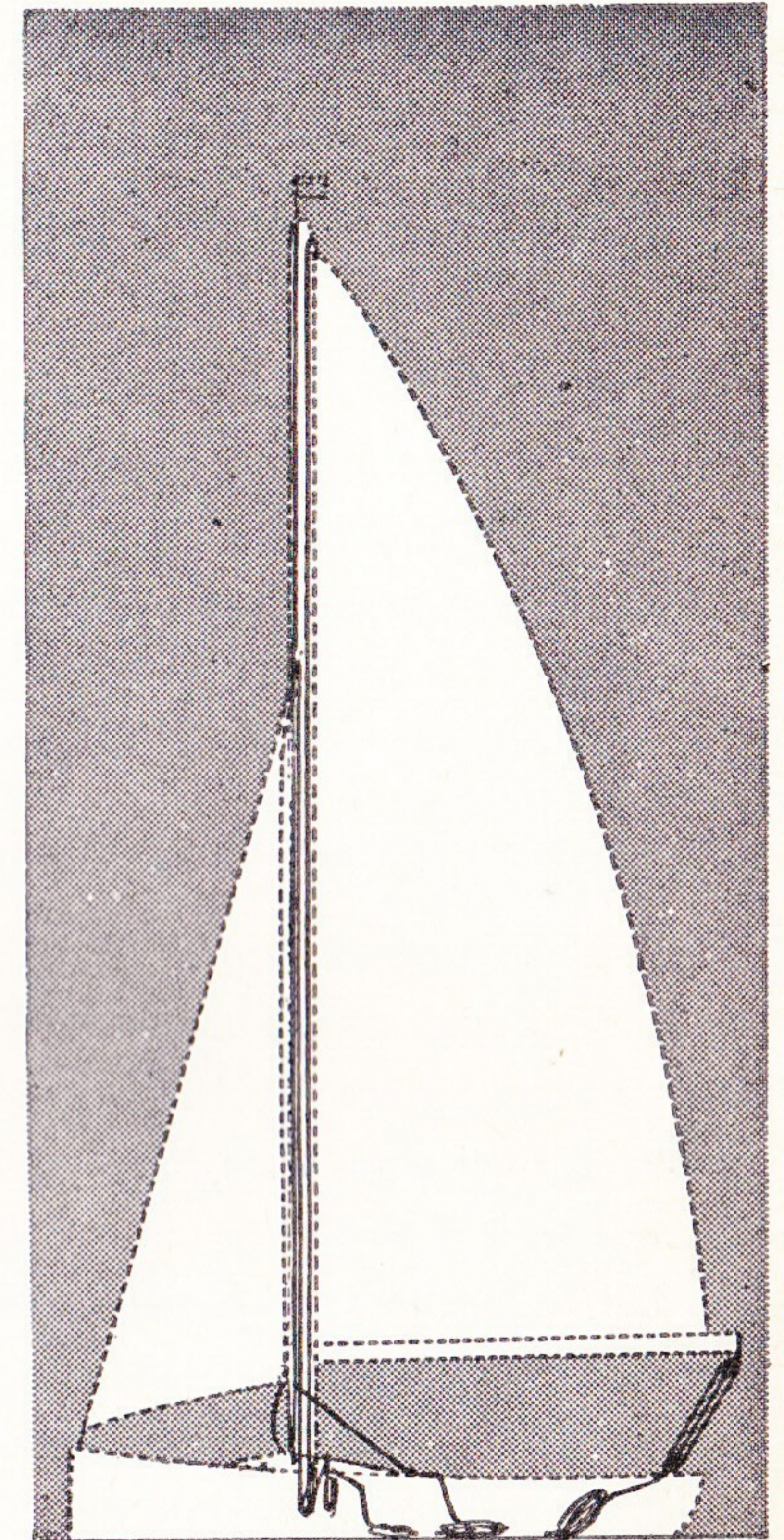

Fig. 16. Running rigging

# Hoisting the Sails

## The Mainsail (Fig. 17)

Slide the foot rope into the groove, or the slides on to the track on the boom. When the tack is reached, make it fast by the method provided. By means of the clew out-haul (Fig. 17 — 'co') stretch the foot of the sail fairly tightly, finishing off with a couple of turns and a clove hitch.

The leech line must be left slack.

Insert the battens into the pockets provided on the leech or trailing edge of the mainsail. The length of the battens is stated in the rules governing the class of yacht but generally speaking they should be long enough to hold out the sail but not so stiff that they cause a ridge at the inner edge of the batten pockets when the sail is hoisted. Use a double reef knot to fasten. Make sure the sail is not twisted. Fasten the shackle on to the head board and insert it into the groove. Hoist the sail and then slide the boom on to the gooseneck and haul down until the luff rope is tight.

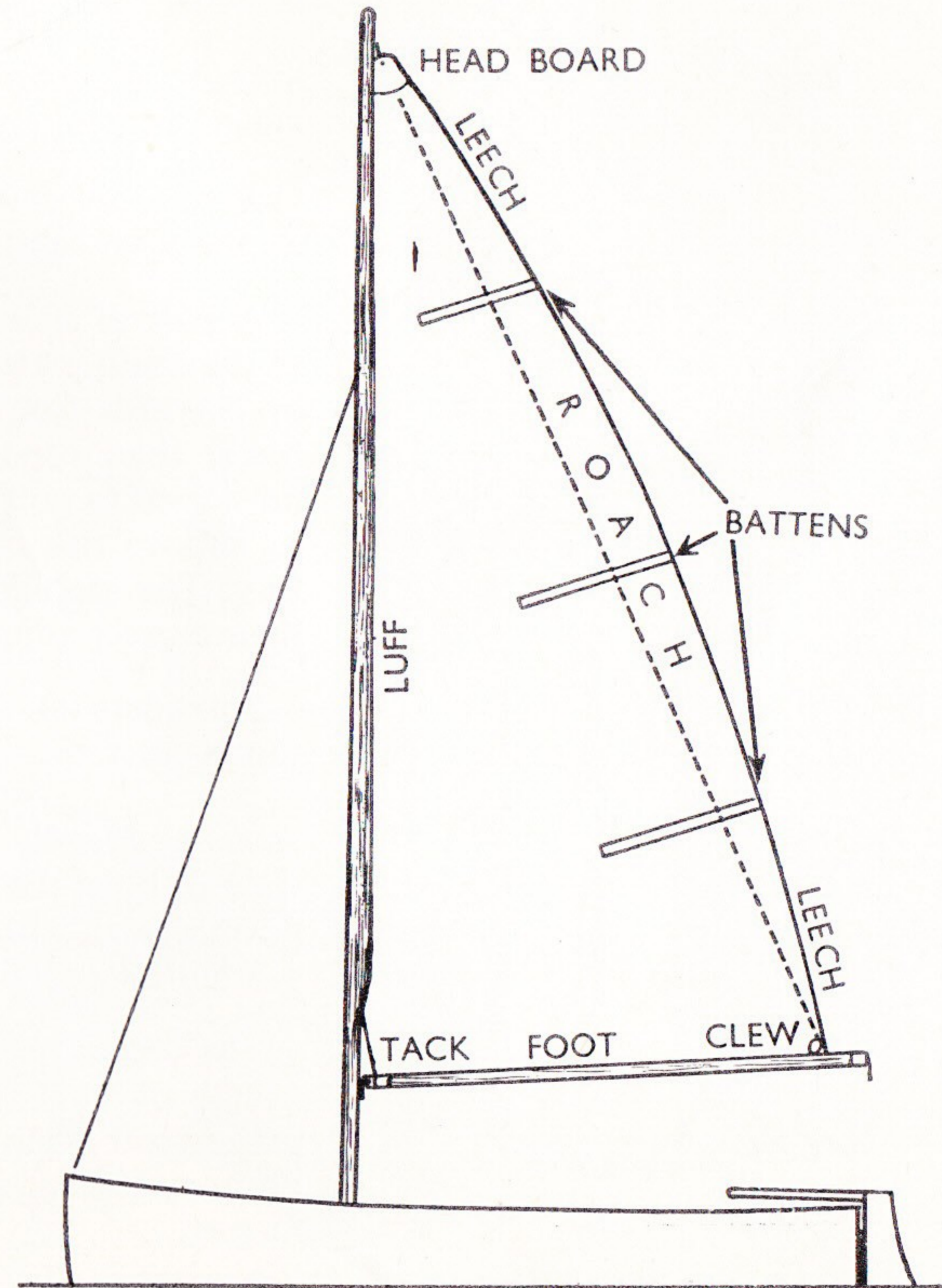

Fig. 17 The Mainsail

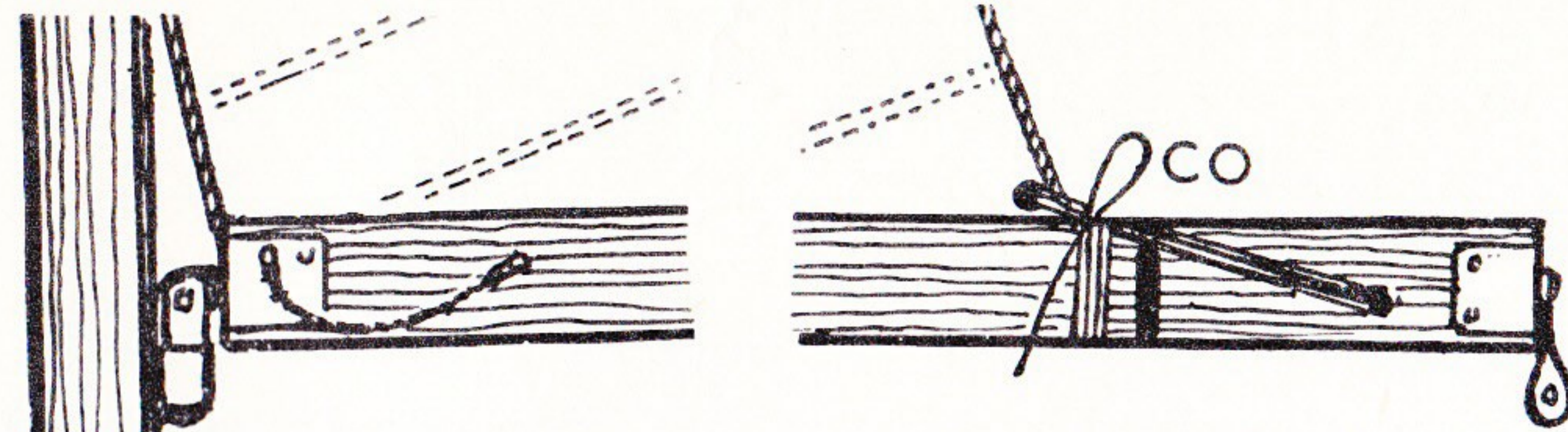

Fig. 18. Fore and aft ends of boom showing methods of holding sail fast

### The Jib

This is hoisted by the halliard which runs through a single block (Fig. 19) at the top of the forestay and down to a cleat on the mast. On most modern craft the halliards run down inside the mast.

Secure the tack in position. Clip the jib hanks on to the forestay. Fasten the halliard to the head of the sail and hoist. Make sure the sail is not twisted. Haul on the halliard until the luff is taut.

Run the sheets through the fairleads (Fig. 19 'F') and tie with a figure of eight knot.

### Spinnaker

Large full triangle sail of very light material set forward of the mast in place of a jib when the boat is sailing on a run or broad reach. It has its own special halliard positioned above that of the jib and its own sheets (*guys*) which are usually led back to the after end of the boat. A spinnaker pole with its own uphaul/downhaul is used to boom the spinnaker to windward.

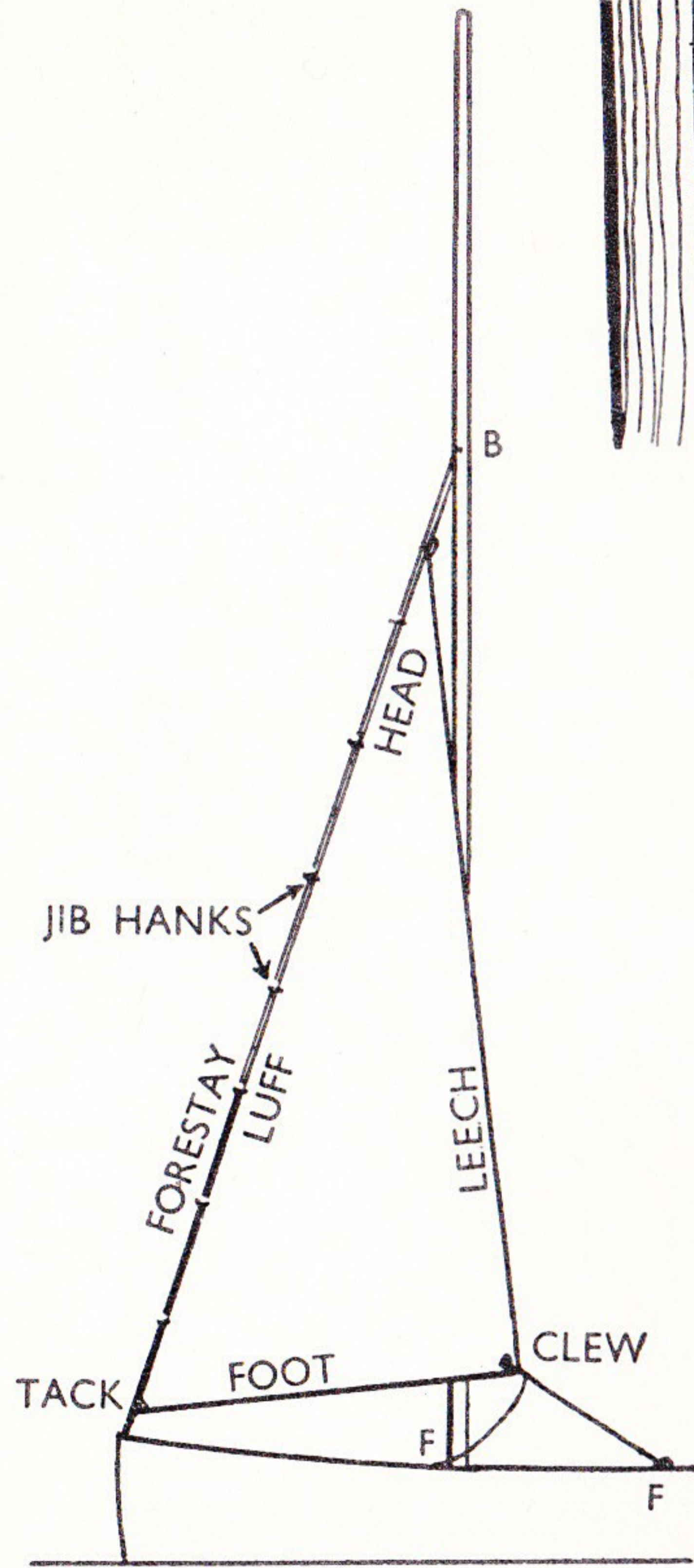

Fig. 19 The jib

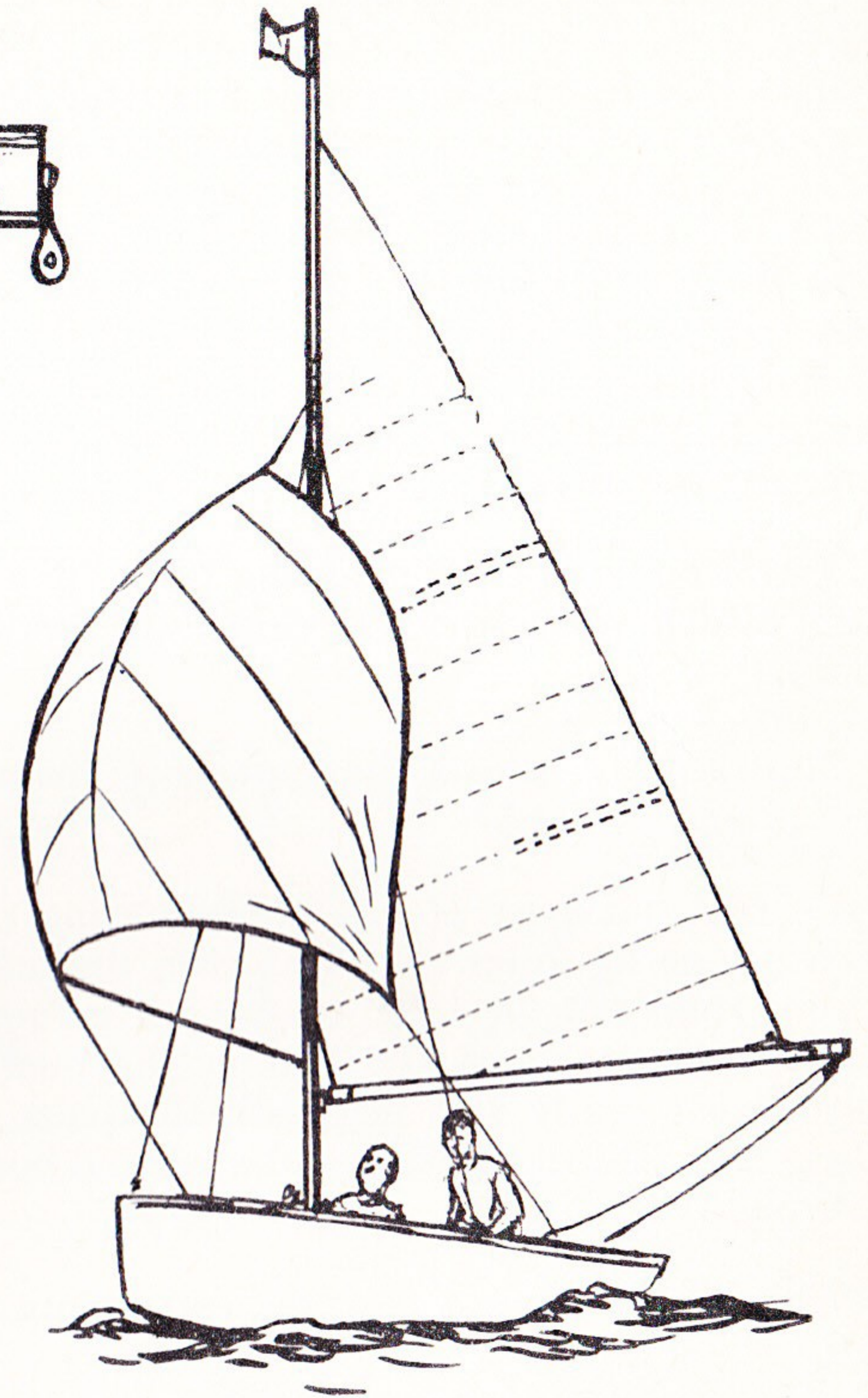

Fig. 20 The spinnaker

# Reefing a Sail

It is wise to practise reefing while the boat is safely on a mooring so that you become familiar with the procedure.

To reef a boat fitted with a sliding gooseneck (Fig. 21A), turn the boat's head into the wind. Slacken the downhaul and ease the halliard. Ease the boom off the squared portion of the pin and roll the required amount of sail round the boom. Replace the boom as before, haul in the halliard and refix the downhaul.

Another form of roller reefing (B) is by a ratchet attachment which winds the sail round the boom like a roller blind.

Illustration C shows the foot of a mainsail fitted with reef points.

To reef this type of sail, after putting the boat's head to wind, partly lower sail. Tie down the luff cringle to the boom. Haul out the leech of the sail before tying the reef pendant firmly round the boom. The bunt of the sail is then furled neatly and tied with the pairs of reef points. These must be tucked between the sail and boom as shown — not round the boom.

When shaking out a reef, the reef points must be untied first.

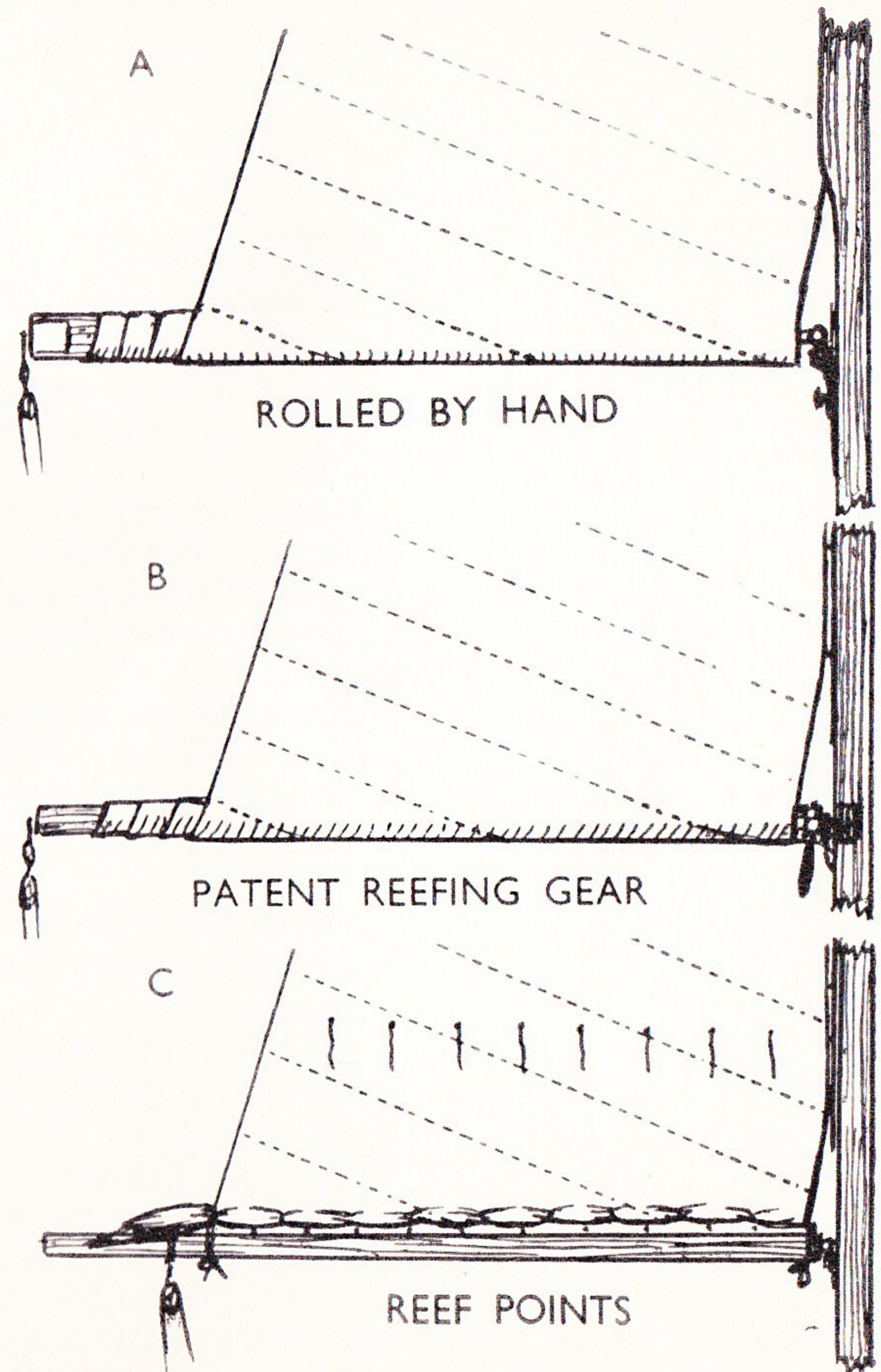

Fig. 21 Different methods of reefing a sail

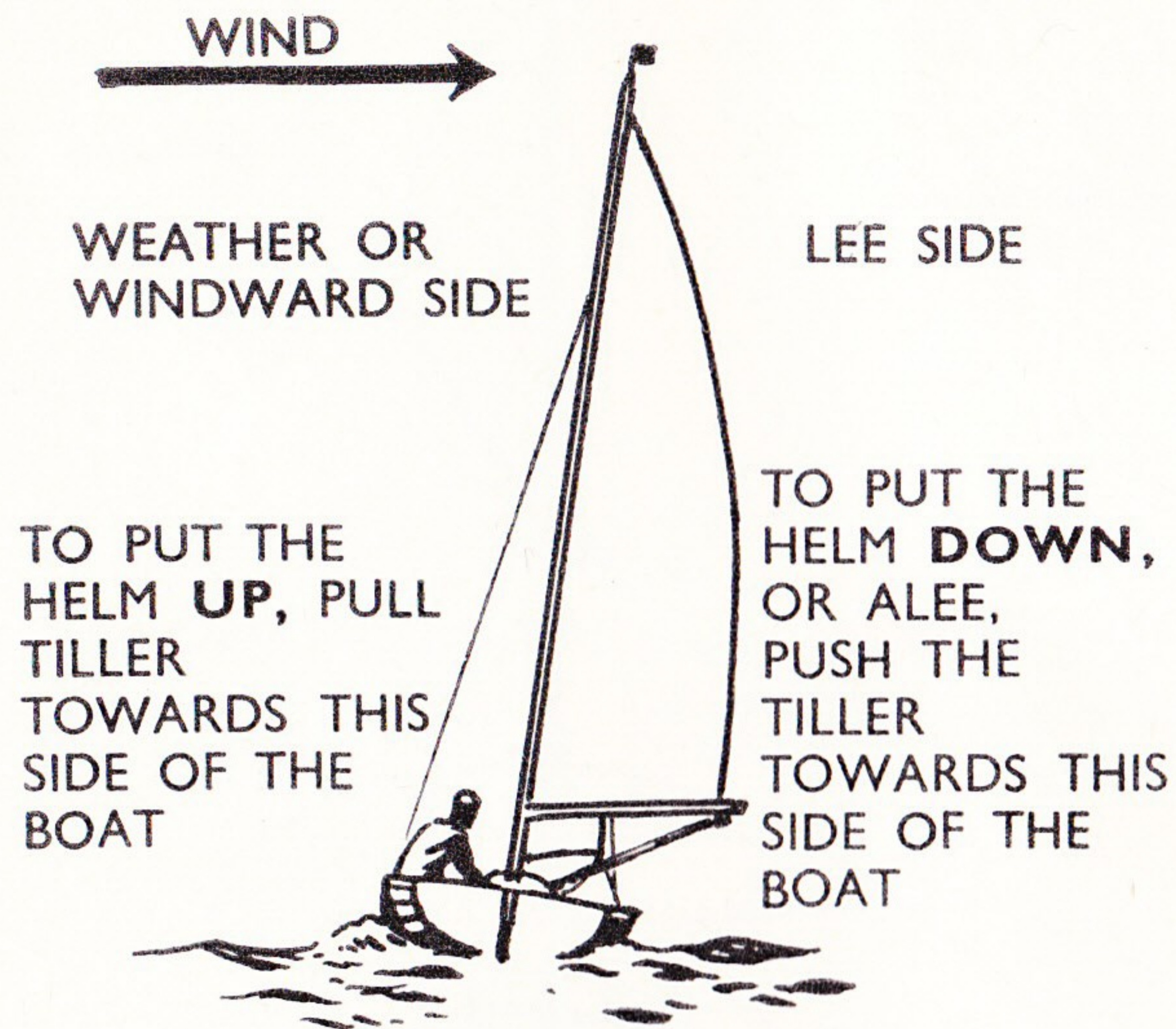

Fig. 22 Wind and helm

## The Wind

When the boat is under way, i.e. moving through the water with steerage way, the terms *weather* or *windward*, and *lee* are used; thus there is weather bow, etc., and lee bow, etc. Fig. 22 illustrates the terms *up* (to windward) and *down* (to leeward). Thus to put the helm up means — pull the tiller towards the weather side; this will turn the boat's head away from the wind (bearing away). Putting the helm down brings the boat's head nearer the wind (luffing up).

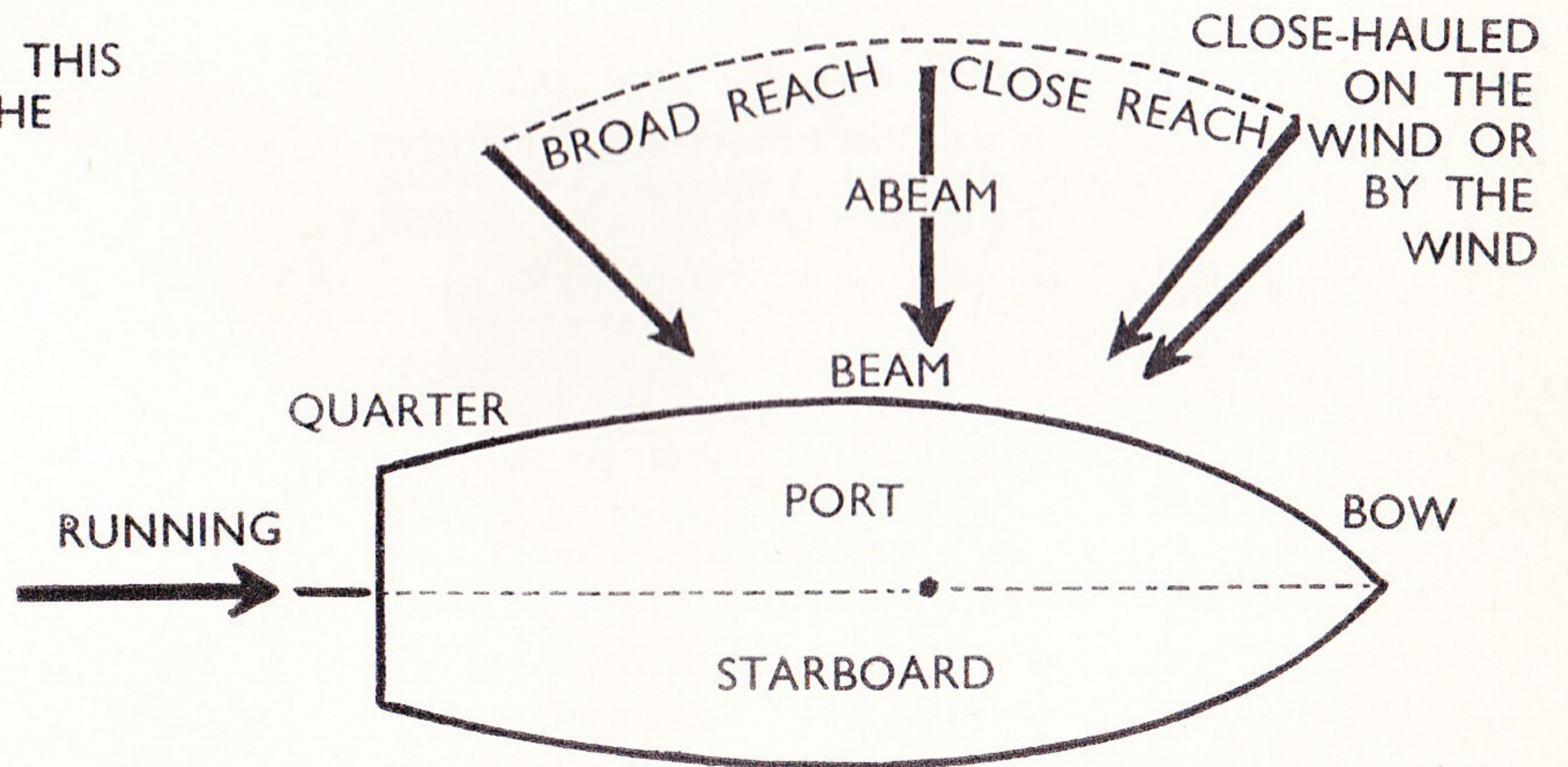

Fig. 23 The different points of sailing (arrows show wind direction)

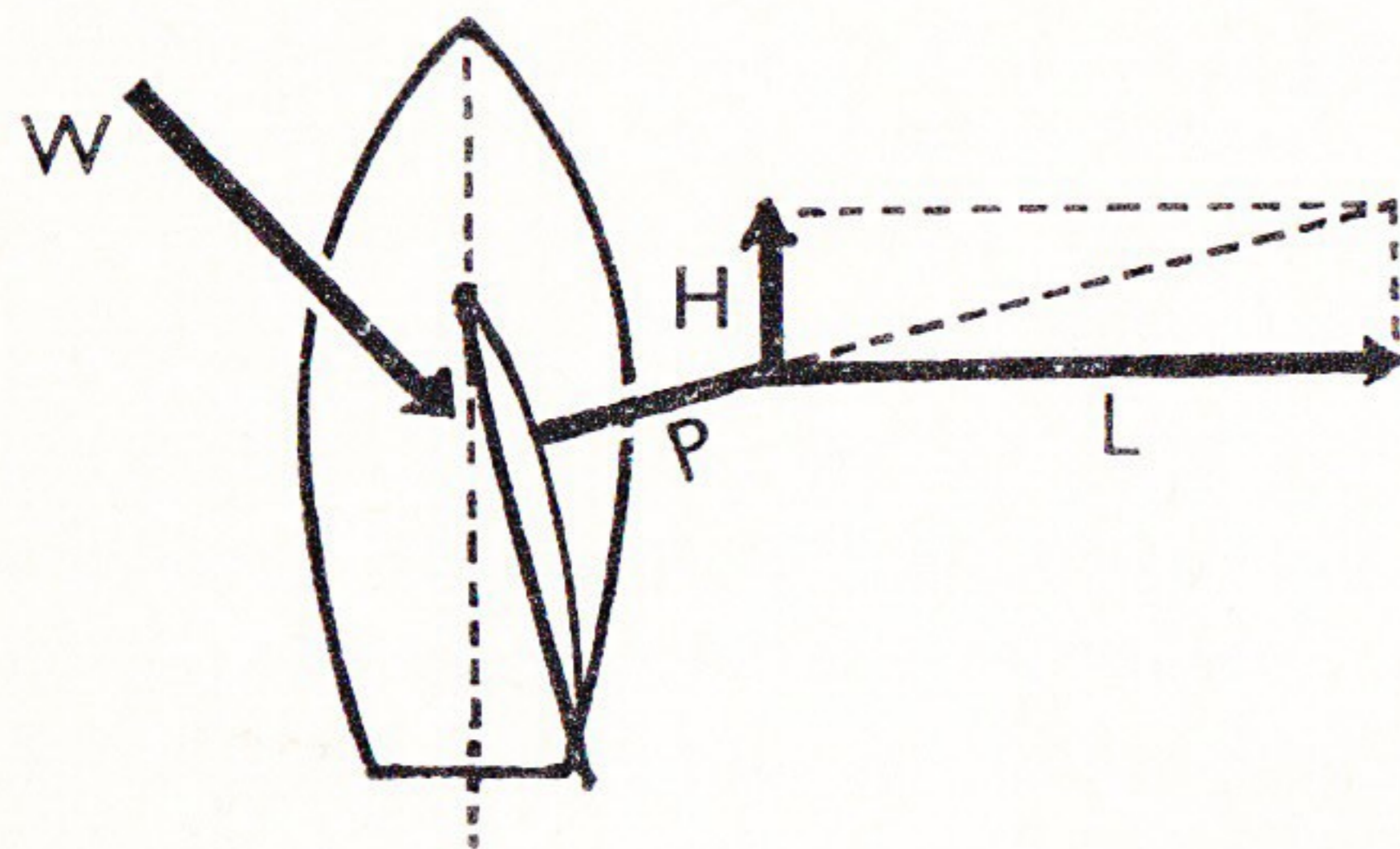

Fig. 24 Wind ahead

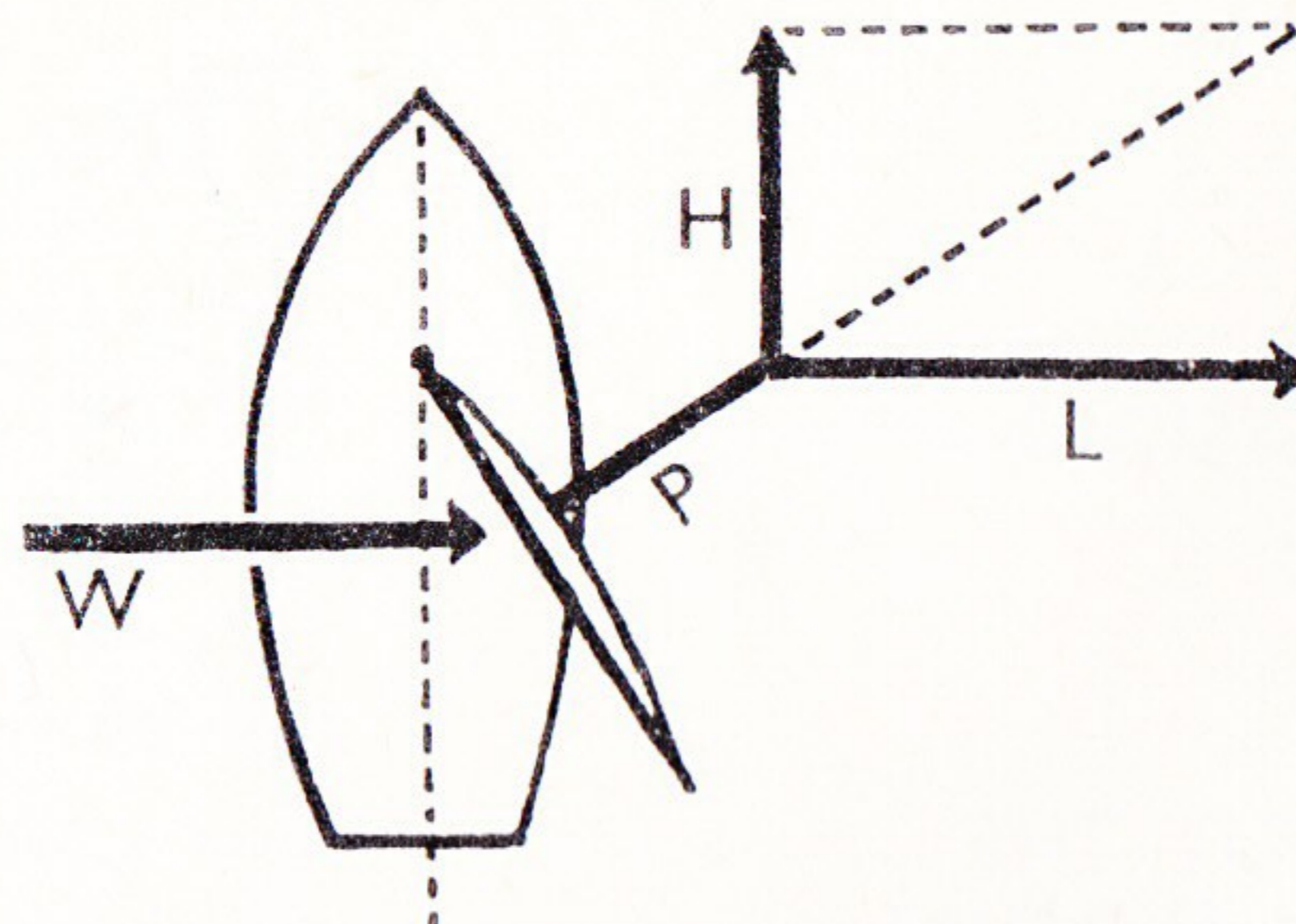

Fig. 25 Wind abeam

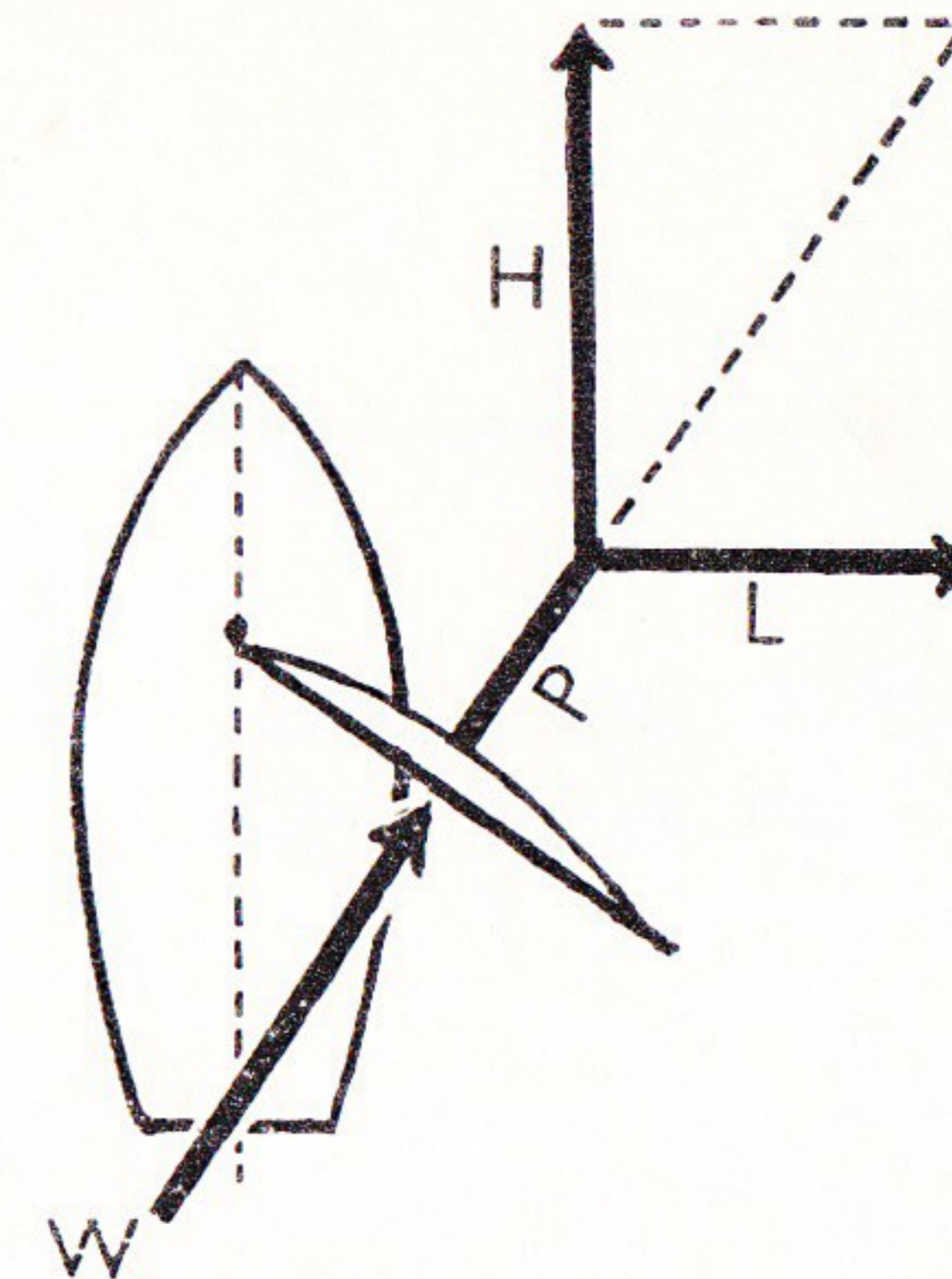

Fig. 26 Wind astern

Wind pressure on the sails exerts force (P) at right angles to the sail surface, see diagrams above.

With the wind more aft the boat's headway (H) increases and the tendency to make leeway (L) decreases.

### Action of the Rudder

The boat's direction through the water is controlled by the rudder, which is operated by moving the tiller. The diagram shows how the pressure of the water on the blade of the rudder tends to swing the boat's stern sideways, thus turning the boat's head and altering course. A boat pivots at a point forward of centre, roughly around the mast.

When a boat is going astern the rudder acts in the opposite direction. This is an important point to remember when getting under way or 'in irons'.

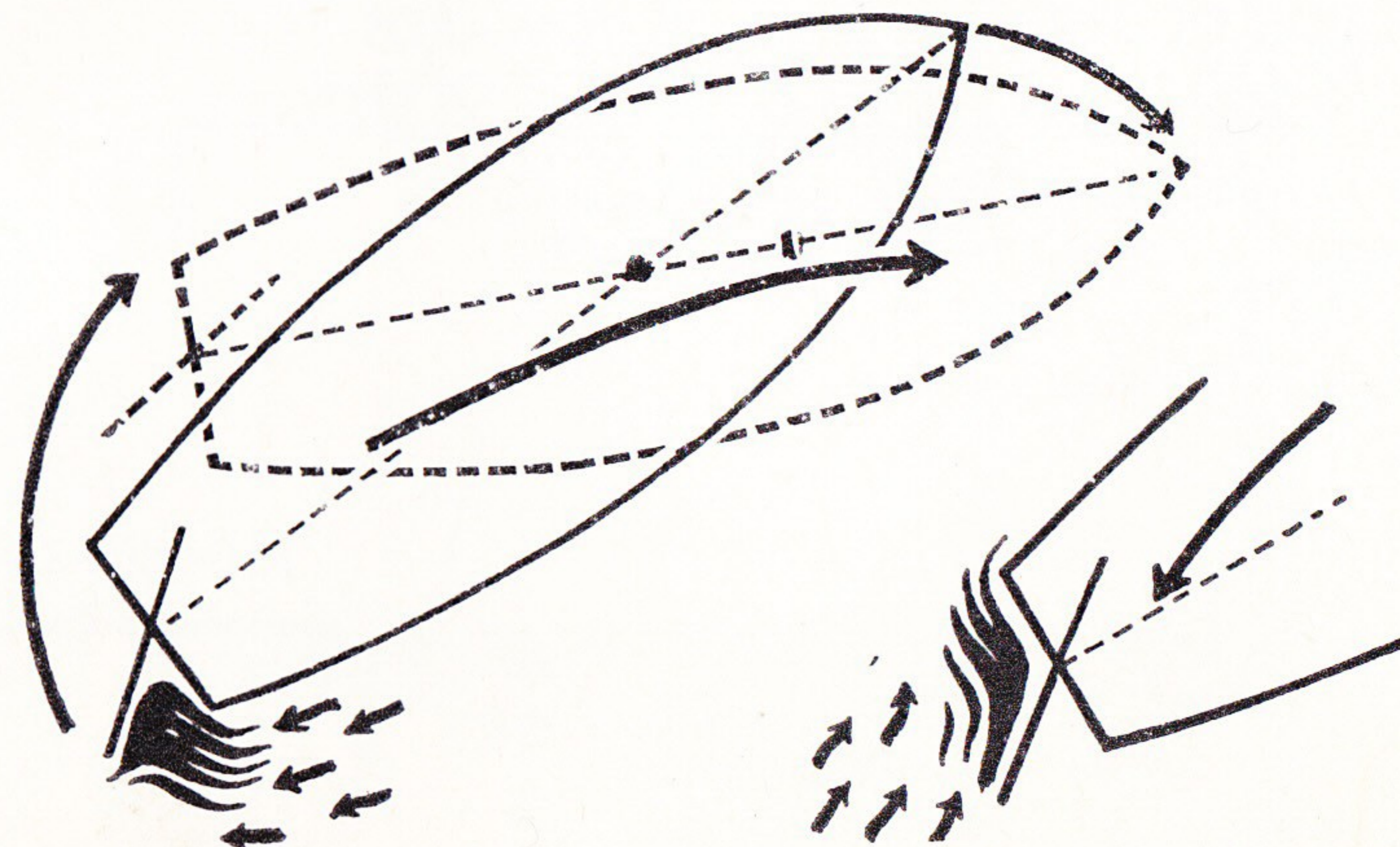

Fig. 27 (a) Action of rudder (b) Action of rudder when going astern

## Balance and Trim

The forces directed upon the boat by the wind through its sail can be calculated to act through a point in the sails known as the centre of effort (C of E). The boat also has a centre through which its resistance to sideways movement may be said to act. This is its centre of lateral resistance (C of LR).

The C of E lies in the mainsail, at about one third of the height of the sail, and the C of LR usually lies in the centre-board or keel, for the lateral resistance depends on the boat's shape under water.

In a well-balanced boat the C of E should be very slightly aft of the C of LR. This ensures that if the tiller is left for a moment, the boat will come head-to-wind. If the boat has too much canvas forward, it has 'lee helm' and the boat's head will turn away from the wind into what could prove a very dangerous situation.

Fig. 29 shows the main forces when a boat is sailing. The sail interrupts the flow of the wind, some spilling to waste, the rest tending to heel the boat to leeward and push it sideways. Water pressure on the underside of the boat helps to offset the heeling. The centre-board offers resistance to the leeward drift and the result is that the boat tends to drive forward. A broad-beamed boat has less tendency to heel than a narrow boat.

*Fig. 28 The C of LR is altered by partly raising the centre-board*

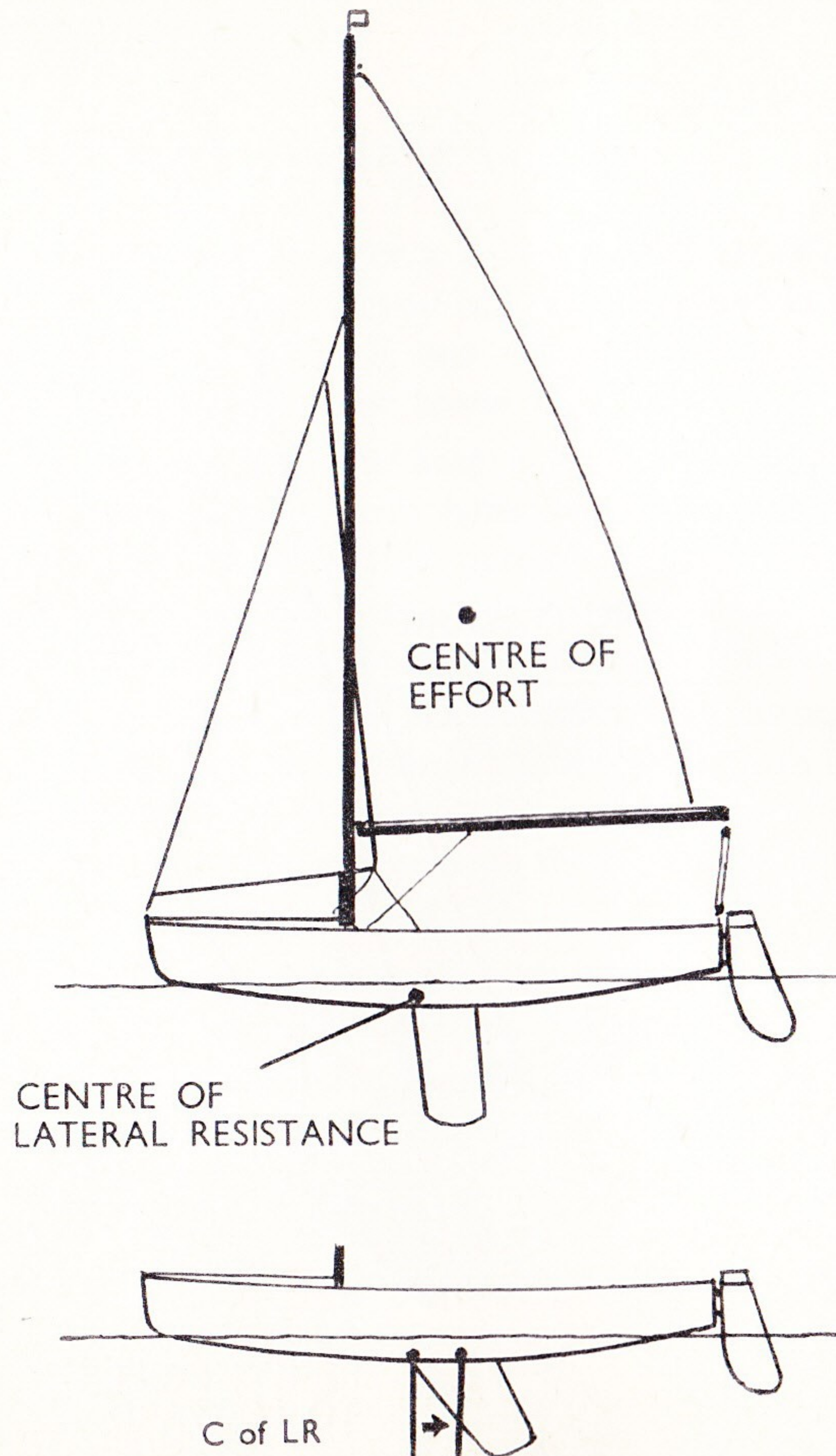

### Close-hauled

The C of E is fairly close to the mast, the centre-board should be fully extended and the helmsman and crew should move as far forward as possible to hold the bows in the water, in order to bring the C of LR as nearly as possible below the C of E. To sail with the maximum efficiency, a dinghy must be kept as upright as possible.

### Reaching

When the mainsail is eased off, the C of E moves slightly aft, so the helmsman and crew should also move aft. The centre-board should be partly retracted, thus swinging its area aft. The helmsman can feel to what extent these adjustments must be made by the pressure he has to exert on the tiller to keep the boat on a straight course. Very little pressure is needed on the tiller when the boat is correctly trimmed.

### Running

When running, the boat should have as little resistance as possible. The centre-board should be almost fully retracted and the helmsman and crew move further aft.

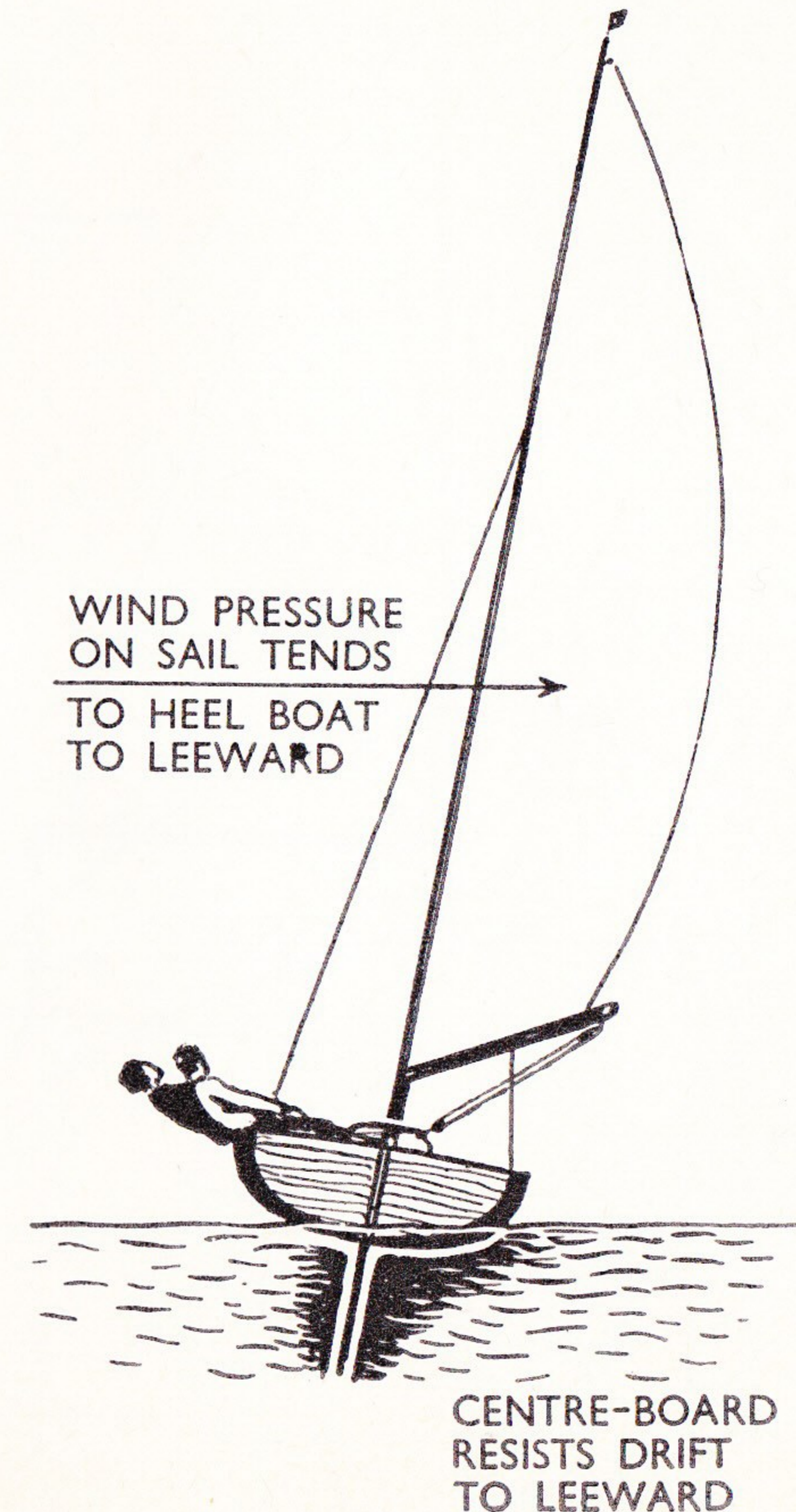

*Fig. 29 The main forces when sailing*

## Getting under way

For your first sail, wait for a light breeze of about seven to ten miles an hour so that you will be able to handle the boat comfortably and safely. A new suit of sails can be ruined by stretching in a stronger breeze than this.

It is assumed that the boat is being launched from a shore, gently sloping river bank or slipway. Every contingency such as wind, tide, current and obstacles cannot be taken into account here, and you should seek help and advice from someone who knows the local conditions.

Hoist the burgee so that it flies well clear of the masthead. Bring the boat on its trolley to the shore and turn its bows into the wind. Slide the foot of the mainsail into the boom, insert and tie the battens, hank on the jib, and hoist the sails as instructed on pages 10 and 11.

One final check over everything on the boat and check your own personal buoyancy, and you are ready:

Check the standard rigging including bottle screw/lanyards, make sure that all the sheets have a stopper knot in the free end, but are otherwise free from knots and tangles. Kicking strap into the slot under the boom and hauled down tight. Make sure the buoyancy bags are inflated and the drain plug closed.

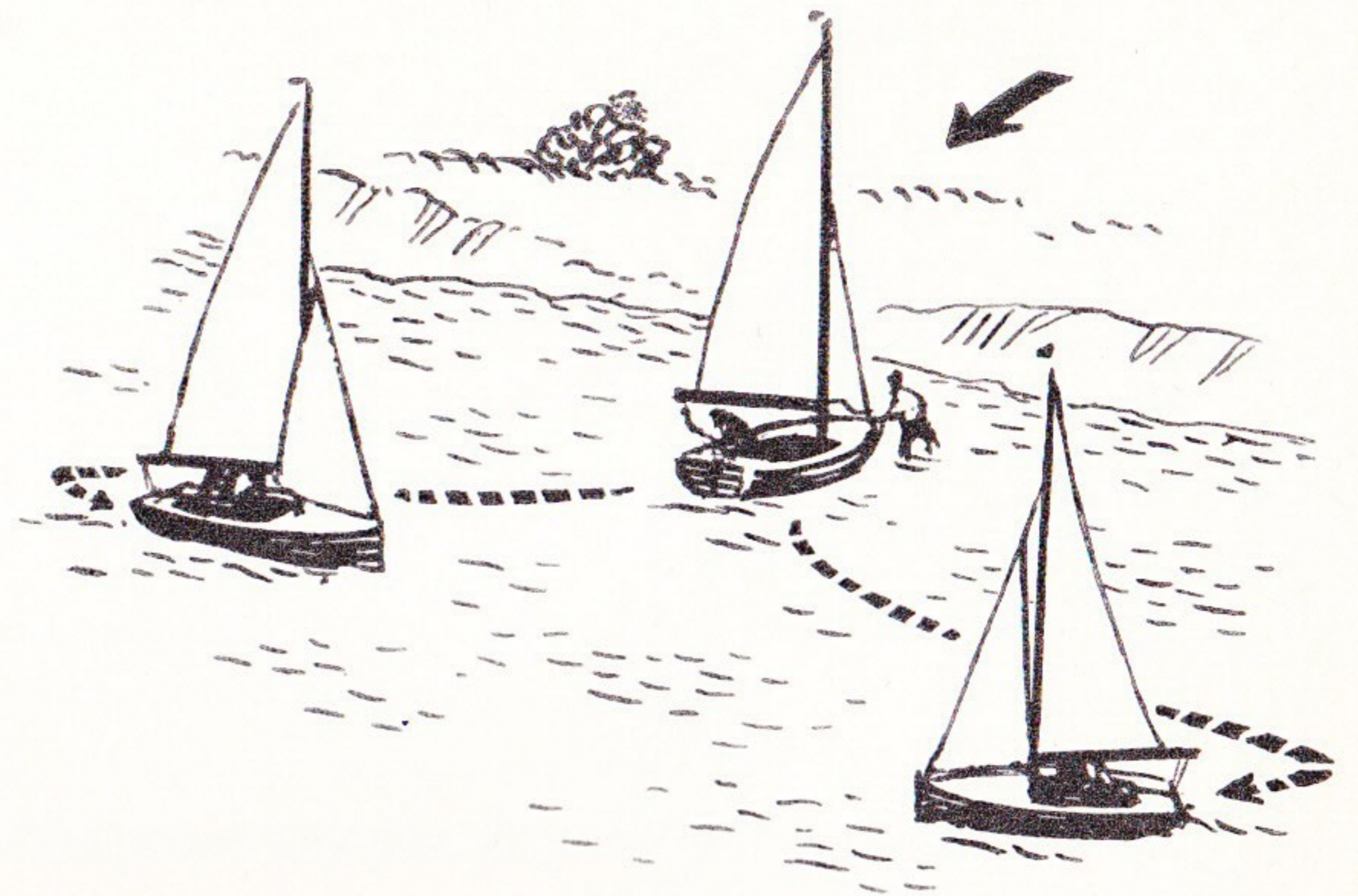
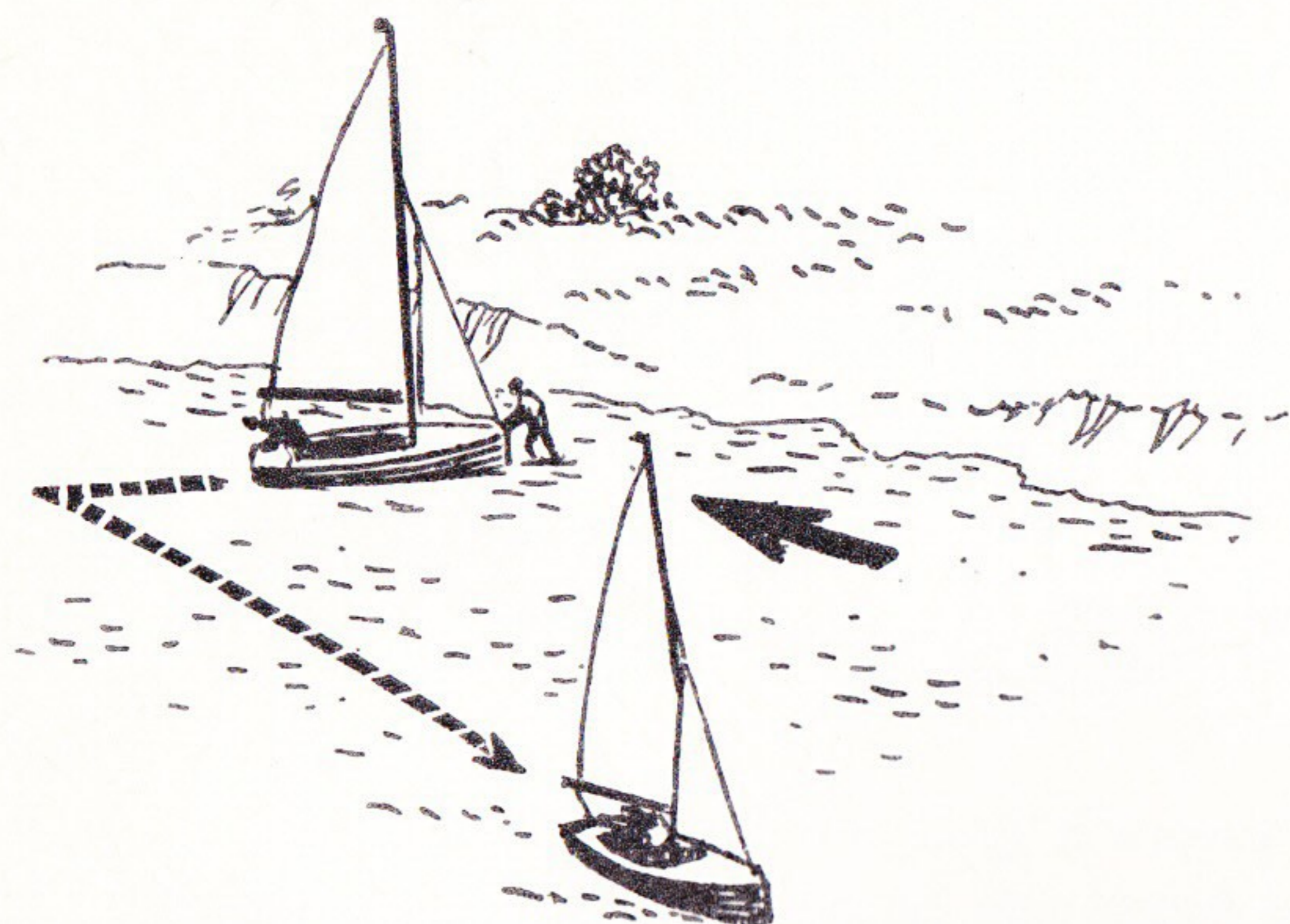

Fig. 30 Launching from a weather shore

If the wind is blowing **offshore** (a weather shore) or **parallel with the shore**, wheel the boat into the water until it floats off the trolley (Figs. 30 and 31). Let the crew take the trolley away to a safe place above high water mark. The helmsman should now climb aboard while the crew holds the bows. The helmsman ships the rudder, inserts the tiller and drops the pin into position. *Leave all the sheets free.* The crew should now give a good push and climb aboard while the helmsman balances the boat.



*Fig. 31 Launching when wind is blowing parallel with shore*

Turn the rudder so that the bows begin to swing in the direction it is intended to sail. Slowly draw the sheets in until the boat stops moving astern. It may be necessary to "back" the jib to make the bows point correctly. As the boat stops and then begins to move ahead, reverse the rudder, allow the jib to draw correctly and lower about half the centre-board.

The main difficulty with an **onshore wind** is to get the boat into water deep enough for the rudder to be shipped, the centre-board lowered fully, and the boat sailing and settled down on a tack into deeper water where there is room to leeward for manoeuvre.

The crew holds the bow into the wind so that the sails cannot fill and force the boat to bear away. The helmsman climbs aboard,

fits the dropping rudder with the blade up, and slots the tiller into the rudder head, pinning it so that it cannot come out accidentally. The crew then pulls hard on the bows, thrusting the boat out into deeper water.

The boat will bear away on a tack as soon as the bow is released and the crew must reach for the jib sheets at once, as he climbs over the side. The helmsman lowers the rudder blade gradually as the water deepens and the crew follows suit with the centre-board until it is fully down.

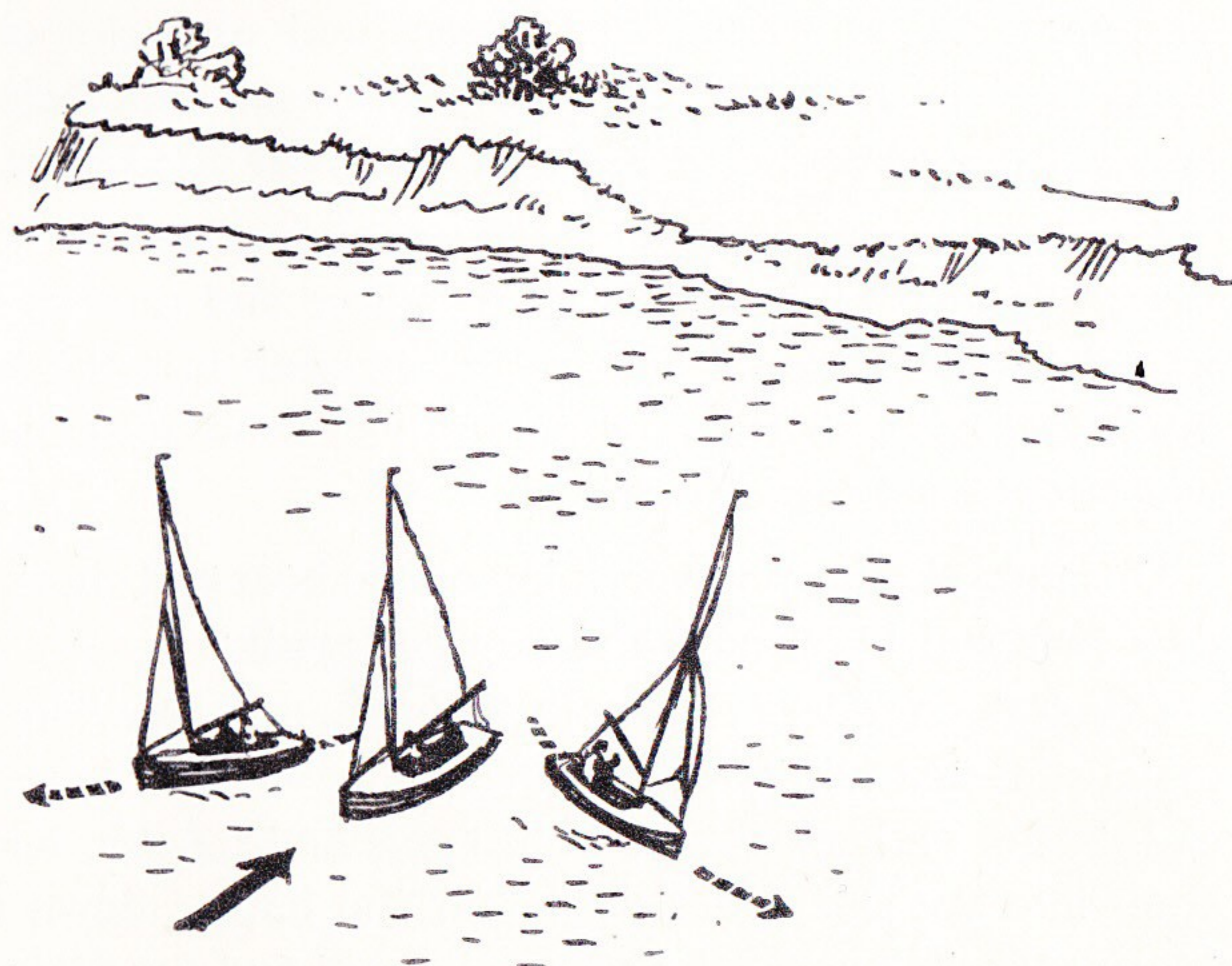

*Fig. 32 Launching with an onshore wind*

Fig. 33 Reaching.  
Centre-board about  
half down



## Sailing the Boat

### Reaching, Fig. 33

If the wind is directly on the beam, a boat is said to be on a reach; when the wind is forward of the beam it is on a close reach, and when the wind is abaft the beam, on a broad reach.

On a close reach, the sheets are eased slightly and the centre-board should be about three quarters down.

On a broad reach, the sheets are eased still more and the centre-board should be about half down.

If sailing in a narrow river or creek it is advisable to keep to the weather shore as it can be very difficult to sail off a lee shore.

Reaching is the easiest point of sailing and ideal for the beginner to get the feel of his boat; it enables the boat to be sailed to and fro along a certain course. Always turn *into* the wind at either end.

### Close-hauled, Fig. 34

To get to a point directly in the eye of the wind a boat must be sailed first on one tack and then on the opposite tack, in a zig-zag course; this is known as beating to windward. Each time the boat changes direction it is said to *tack*.

When the wind is on the port side the boat is on the port tack and when the wind is on the starboard side it is on the starboard tack. A boat efficiently rigged can be sailed at an angle of 45 degrees to the wind.

When sailing to windward the mainsheet and jib sheet should be pulled in tightly (closehauled), and the centre board pushed right down.

Keep the boat as upright as possible; if it heels it will slow down and make some leeway.

The helmsman sits on the windward side, and if the boat heels as the wind freshens, the crew must join him. Both should have their feet safely under the toestraps.

Steer by watching the front edge (luff) of the jib, keeping it smooth and full. When sailed too close to the wind (pinched) the luff will shake and flutter, and the boat will slow down or stop. The ideal point of windward sailing is found by turning into the wind until the luff just starts to shake, and then bearing away enough only to smooth it out.

The wind seldom blows truly from one point, and the windward course must often be altered to follow each shift closely.

Excessive heeling to sudden gusts may be met by luffing into the wind or by easing the mainsheet, or both these together so that the wind is spilled. The jib sheet should not be eased except as a last resort to prevent capsize.

The boat must always be kept moving ahead because it will answer to movements of the tiller whilst it has steerage way. When the boat is stopped it cannot be controlled and may be overpowered.

If a squall is prolonged and dangerous, lower the mainsail and run before the wind under jib only.

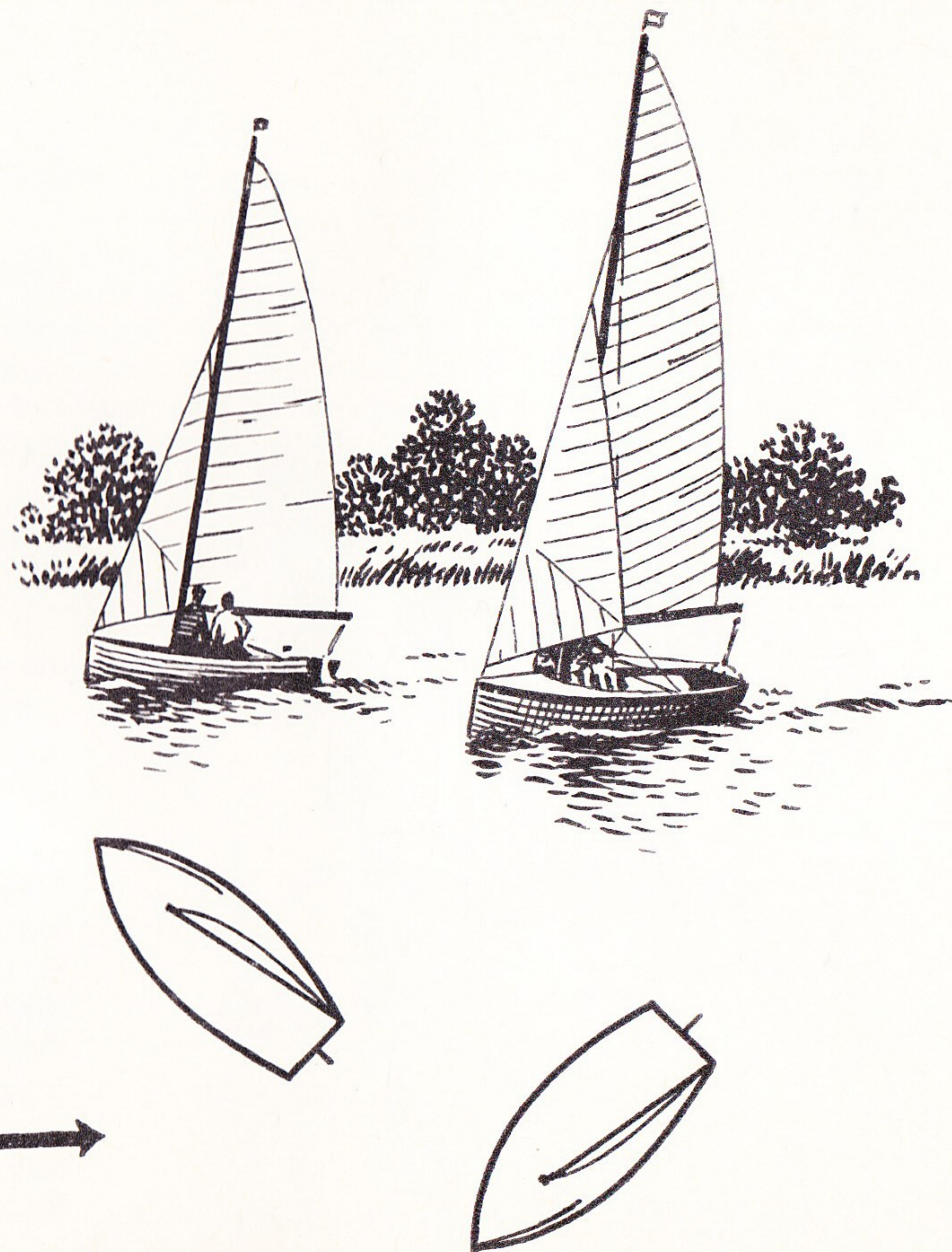
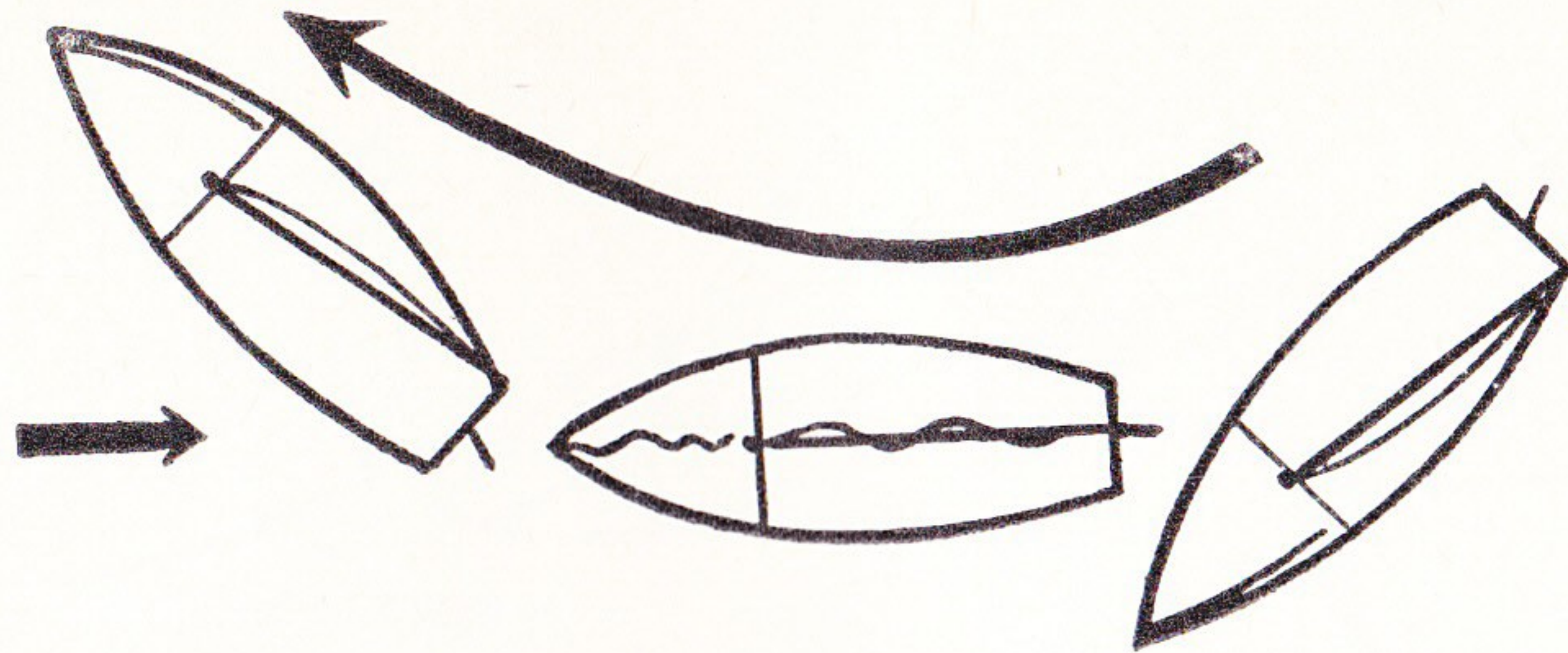

Fig. 34 Close-hauled Centre-board fully down



*Fig. 35 Tacking*

When it is time to come about, to bring the wind on the other side of the boat, it is wise to sail a degree or two more away from the wind so that there is plenty of way on. If there is a crew warn him by calling 'Ready about'. The lee jib sheet should be let go when the jib luff quivers, and the other sheet should be hauled in.

During this operation the crew should gently move to the opposite side of the boat, which now becomes weather side. If this has been done successfully the boat will immediately gather way on the new tack, but in the early stages, or in light winds, she may stop head to wind, known as being in irons.

If this happens the crew should pull the jib to windward, known as "backing the jib", and the boat will then continue to tack.

### **Running, Fig. 36**

When a boat is sailing with the wind directly behind, or one or two degrees on either side of the stern, it is said to be running. As the boat is running away from the wind, it seems to lose its power and conditions become quieter and this may lull the new helmsman into thinking that it is easy. Probably more accidents occur on this point of sailing than any other.

*Fig. 36 Running.  
Centre-board  
up*

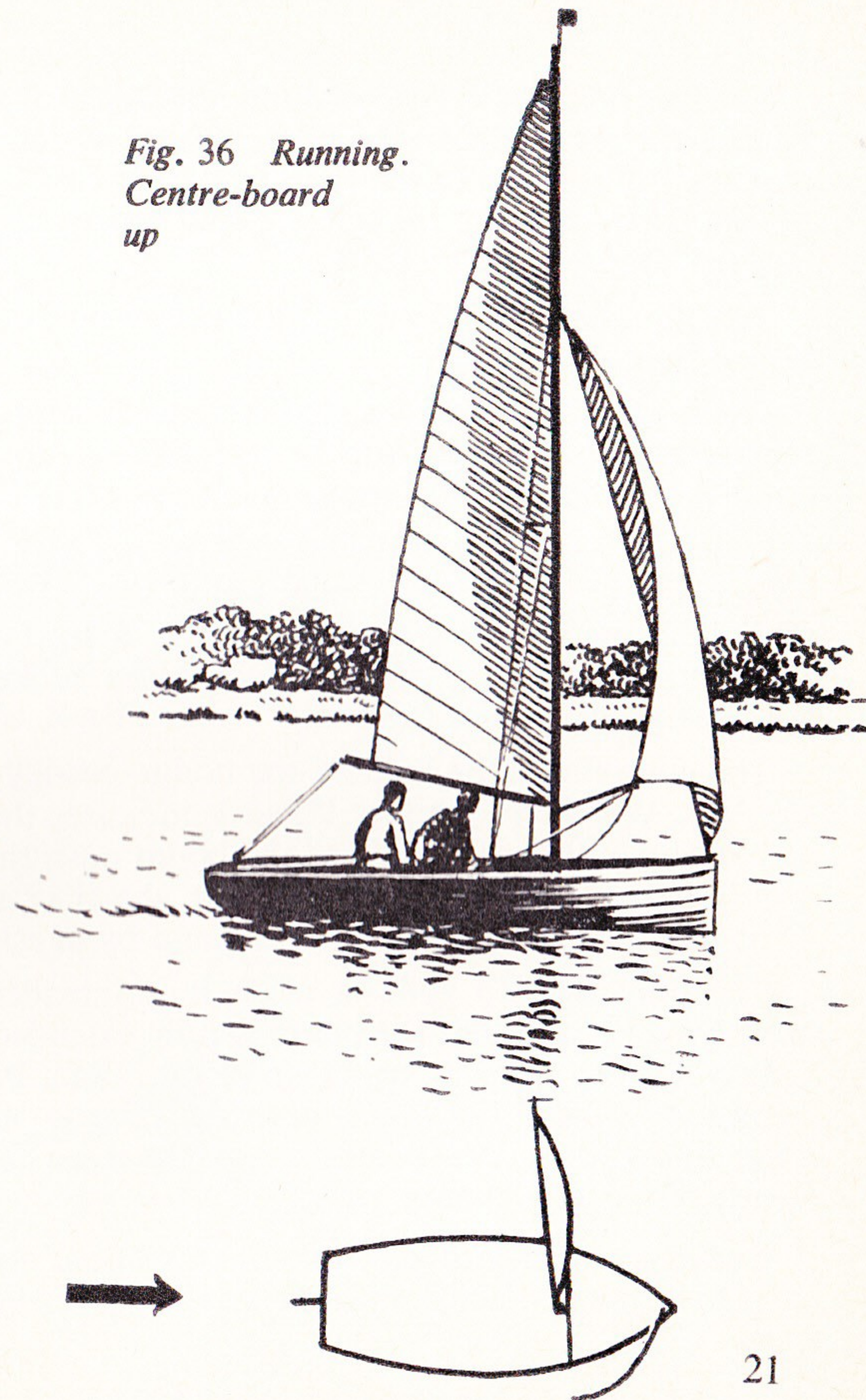

The mainsheet is eased off until the boom is almost at right angles to the boat, but not so far that the mainsail chafes on the shrouds. If eased off too far the head of the sail will spill the wind and the boat will roll violently.

The jib sheets are eased and the centre-board pulled right up.

When running, your weight should be kept farther aft than usual but be careful not to cause drag by digging the transom in.

If the wind gets round the back of the mainsail — running by the lee — it may swing across unexpectedly. This is an accidental gybe and even in a light wind is unpleasant. In a strong breeze it can cause broken shrouds, dis-masting or capsize the boat.

The crew should be holding the boom steadily against the shrouds. Watch the burgee. When it indicates that the wind is blowing on the same side as the boom push the tiller *very gently* towards the boom. If you use the tiller roughly the boat will start to roll violently and end by capsizing.

The only time to gybe is when it is intended. To gybe cleanly make sure that the boom is fully extended. Warn the crew who then takes a firm grasp of the boom. Pull the tiller gently away from the boom until the boat is 'by the lee'. Give the order — 'Gybe-oh!', and the crew should then gently swing the boom over.

The helmsman and crew change positions as the boom swings across and adjust the sheets to the new wind direction.

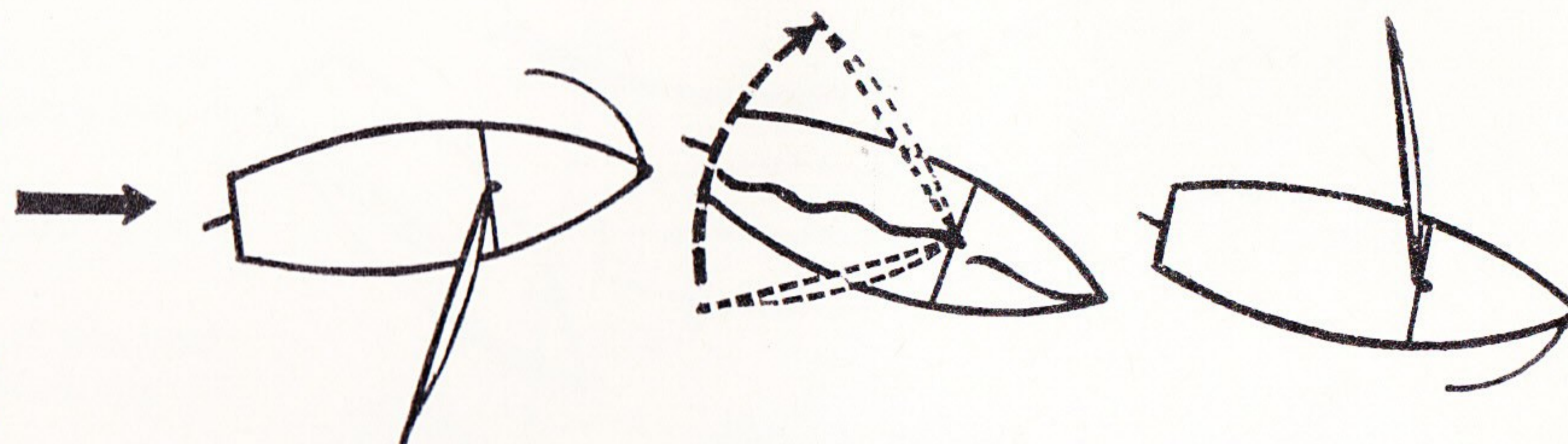

Fig. 37 Gybing

In a perfect gybe the boat does not roll and loses hardly any speed.

In violent wind conditions it is safer to tack than to gybe. Gradually turn the boat towards the wind, slowly hauling in the sheets until, still moving fast and with centre-board down, the boat is ready to tack. Under conditions like these it is important to sail the boat right round, keeping up speed all the time. If you try this manoeuvre merely by turning the rudder, the ship will not have sufficient speed to tack and may stop and capsize.

When running with a crew, the jib may be goosewinged by booming it out on the weather side with a whisker pole. To set, pull the jib over to windward, then insert the spiked end of the pole into the clew shackle; push the pole forward, not sideways, and attach the other end to the mast. Haul on the weather sheet until the boom is at right angles and the sail drawing. The whisker pole must be unshipped before gybing.



*Fig. 38 Against the current. A boat moving at 4 knots against a 3-knot current will only make 1 knot relative to the land (A to A1)*

### **Sailing on Tidal Waters**

The ebb and flow of the tide will have to be taken into account not only because the moving water affects the boat's course, but because in many places at low tide the area for sailing is greatly restricted. It is necessary to find out as much as possible of the local conditions, especially the direction and strength of the current and times of high and low water. Tides are controlled by the moon. Spring tides at the new and full moon have a greater range between high and low water and run stronger on both flood and ebb than neap tides which occur at the first and last quarters of the moon.

Sailing at four knots against a three knot current, the boat will only travel one knot relative to the ground. Sailing at four knots with a three knot current in its favour the boat will travel seven knots. When the current is running across the course being sailed, allowance must be made to counteract the drift. When sailing to windward, the boat will make most headway on the course that has the current on the lee bow.

In shoal water the centre-board gives warning when it touches bottom; often it is only necessary to raise it slightly while passing over a shallow patch. If the tide is flooding, the depth of the water will be increasing.

*Fig. 39 With the current. A boat moving at 4 knots with a 3-knot current will make 7 knots (A to A2)*

With an ebbing tide, speed is essential. If stranded on firm ground jump overboard and push the boat into deep water.

If aground on or near a lee shore it may be necessary to drop all sail and paddle or kedge off, resetting sail again in more open water.

If the current is setting the boat towards another vessel, whether it is anchored or under way, do not risk trying to cross ahead of it; go round the stern.

### **Rules of the Road**

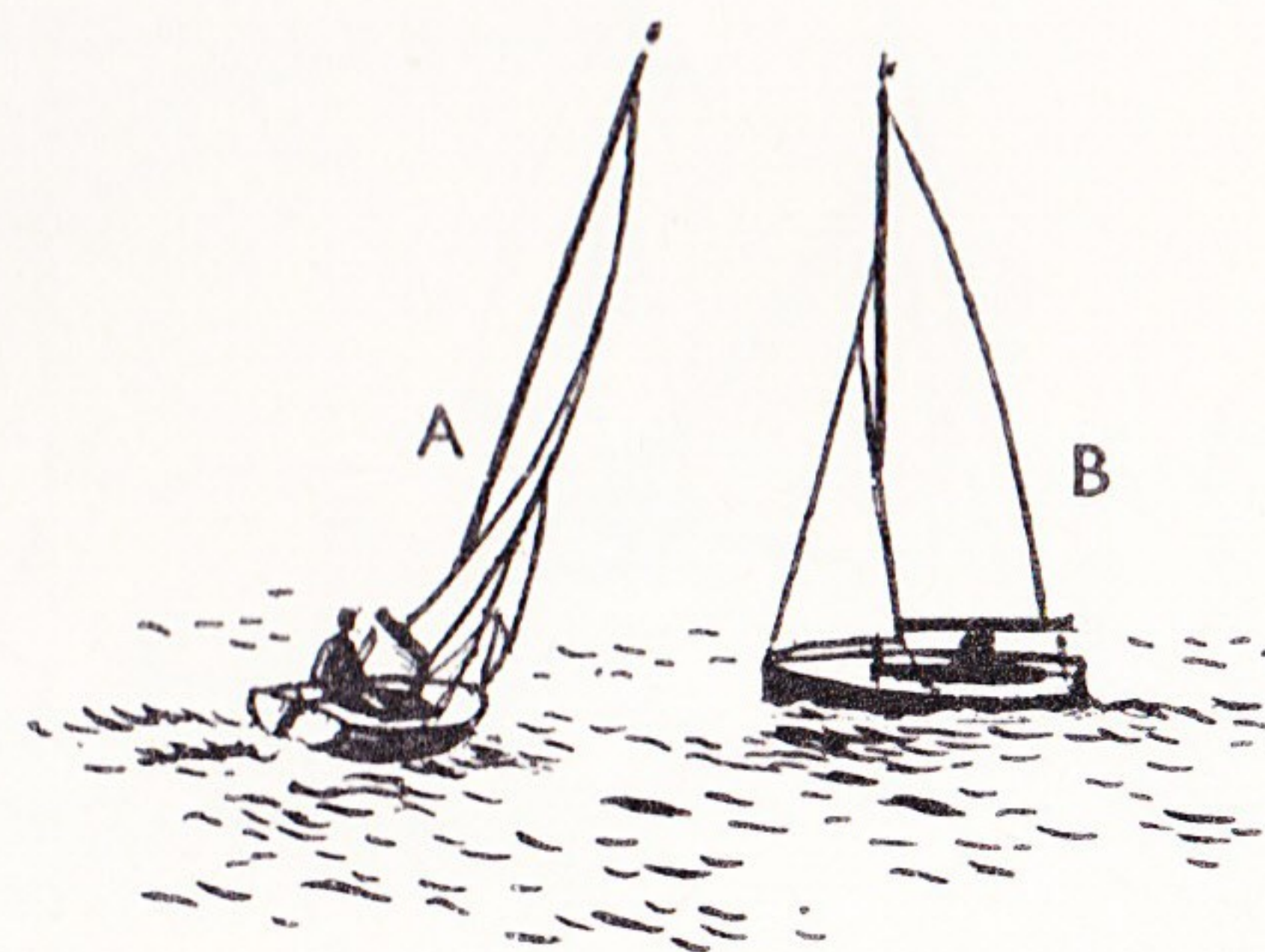

*Fig. 40 Boat A close-hauled on port tack gives way to B on starboard tack*

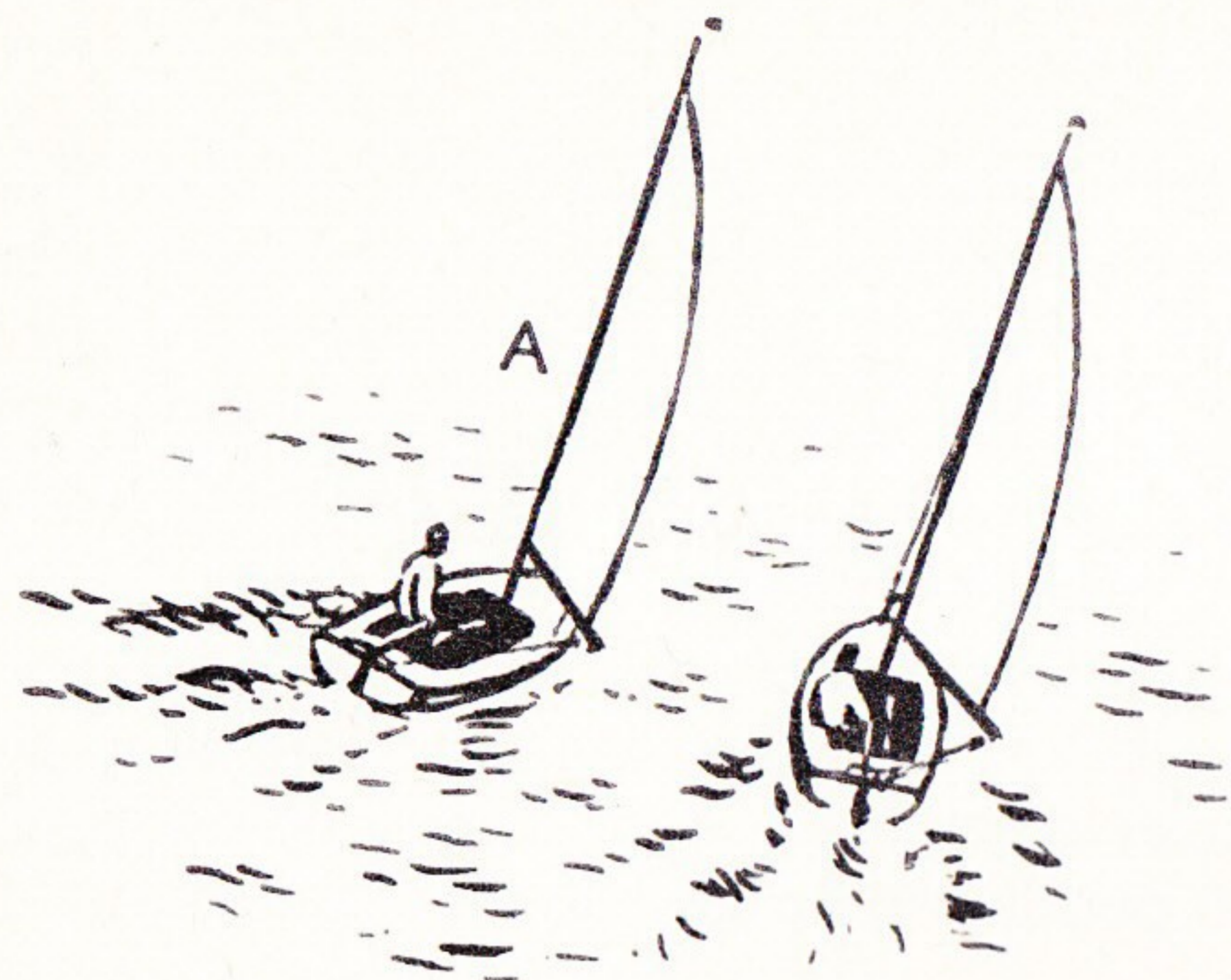

*Fig. 41 When two boats on same tack or gybe are on converging courses, the windward boat, A, keeps clear*

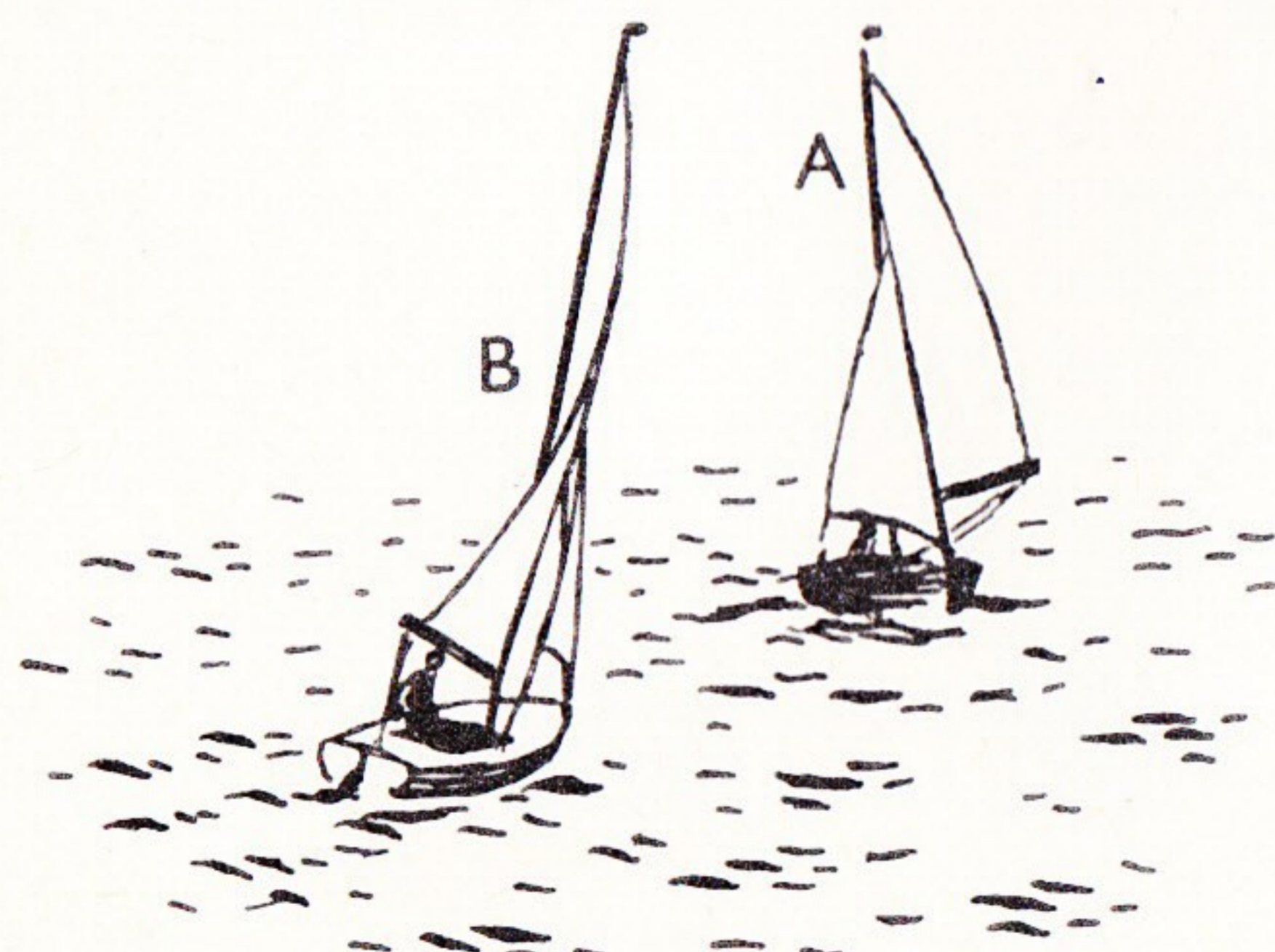

*Fig. 42 Boat A on starboard tack has right of way*

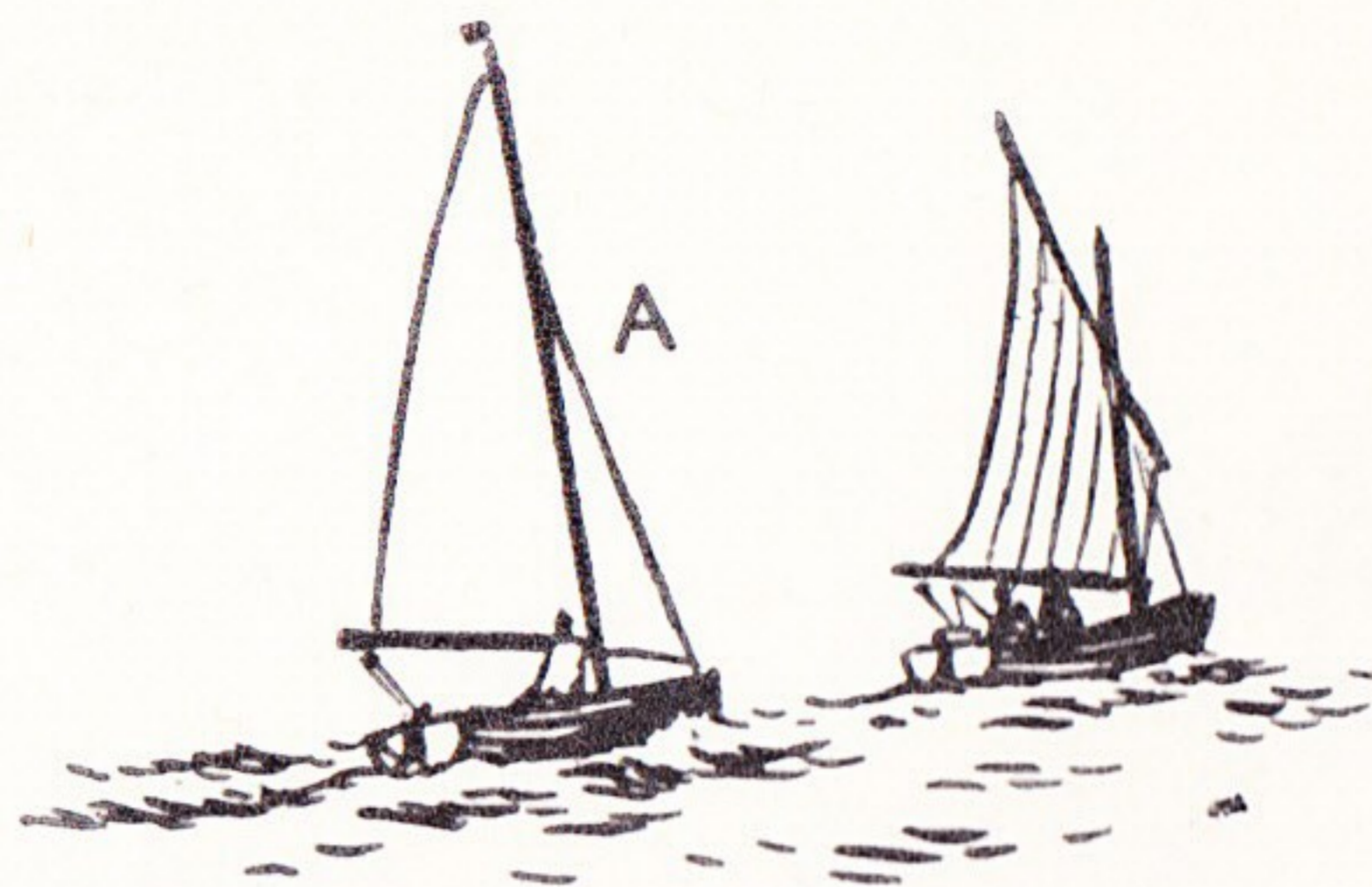

*Fig. 43 Overtaking boat, A, keeps clear*

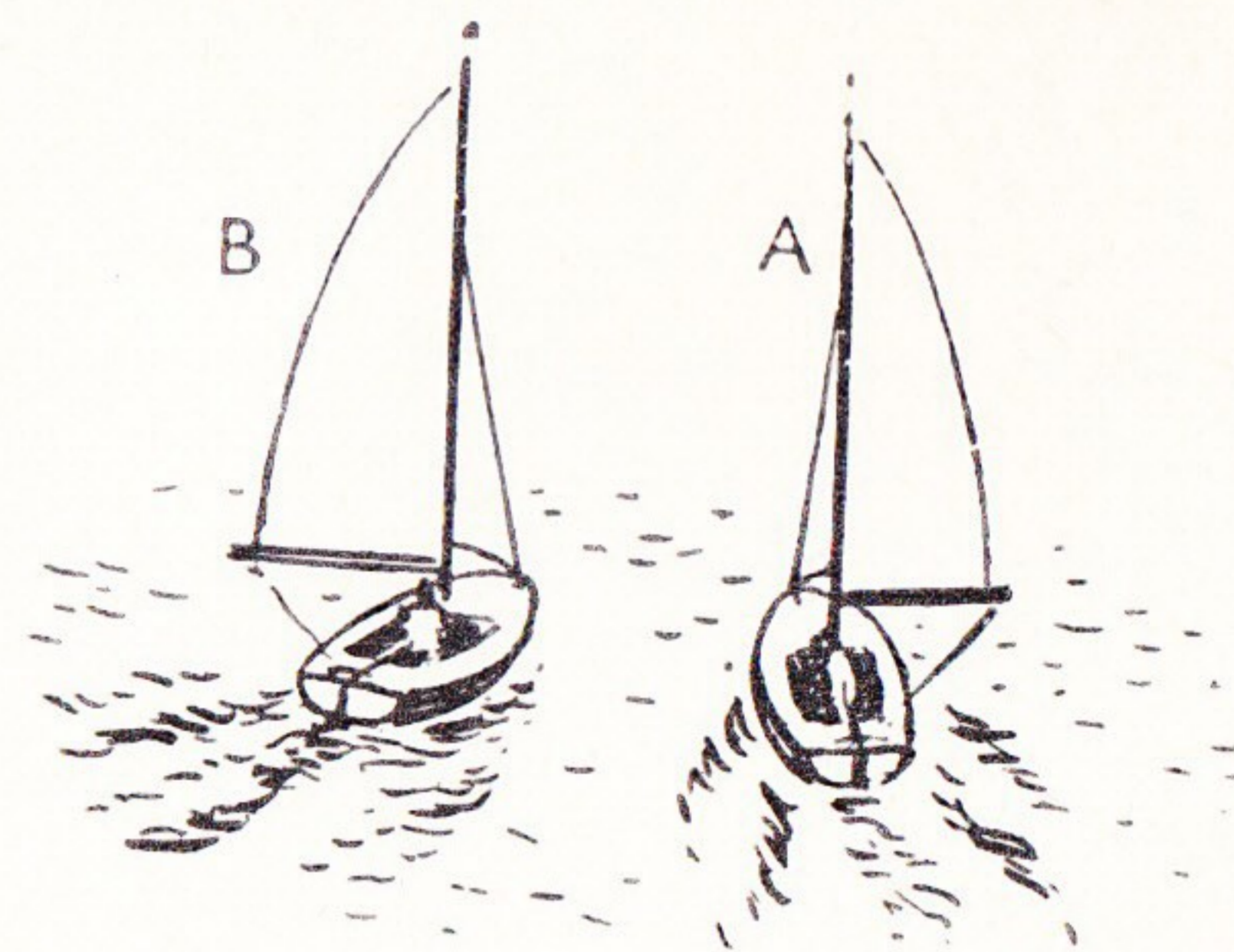

*Fig. 44 Boat A gives way to boat B which has wind on its starboard quarter*

Steam and motor craft should give way to sail, but in a narrow channel this is sometimes impossible, as with their deeper draft they run the risk of grounding.

*Sound signals for steam or motor craft*

- 1 short blast — I am directing course to starboard.
- 2 short blasts — I am directing course to port.
- 3 short blasts — I am going astern.

*Sound signals in fog*

- 2 long blasts — Underway but stopped.
  - 1 long blast — Underway, moving.
  - 1 long blast and 2 short blasts — Unable to manoeuvre.
- A short blast is one of about a second's duration.

When passing large craft be ready to meet their wash end on, either bow or stern, depending on the course being sailed. In the lee of large objects such as trees, buildings or steamers, the boat will probably be becalmed. When the wind strikes again it will be with the sudden force of a squall; the helmsman must be prepared to ease the mainsheet to avoid excessive heel. A safe angle of heel in smooth water can be dangerous in rough water. In the event of the wind strengthening, reef in good time.

# Capsize Drill

1. **HOLD ON TO THE BOAT.** The reserve buoyancy will not allow it to sink but it may be taken away by the wind or tide. Get out of the water on to the hull.
2. Each member of the crew must check that the other is safe. If the crew is hurt or tired or the boat is damaged then **HAIL THE RESCUE BOAT AT ONCE.**
3. To right the boat act as follows:
  - (i) Pull down the mainsail after letting go the halliard or unshackling the headboard.
  - (ii) Pull the centreboard fully down and stand on it holding the gunwhale.
  - (iii) Lever the boat upright by leaning back and moving further towards the tip of the centreboard.
  - (iv) Scramble one of the crew into the dinghy to find the hand bailer or bucket and get some of the water out of the boat.
  - (v) The second crew member climbs inboard (over the stern) as *soon as possible* and helps with the bailing. The boat may be sailed ashore and tipped out or bailed dry if self bailers are fitted.
4. Methods of righting will vary a little with different dinghies and conditions. A practice capsize in calm weather will show which is the best drill to adopt, and will build up confidence.

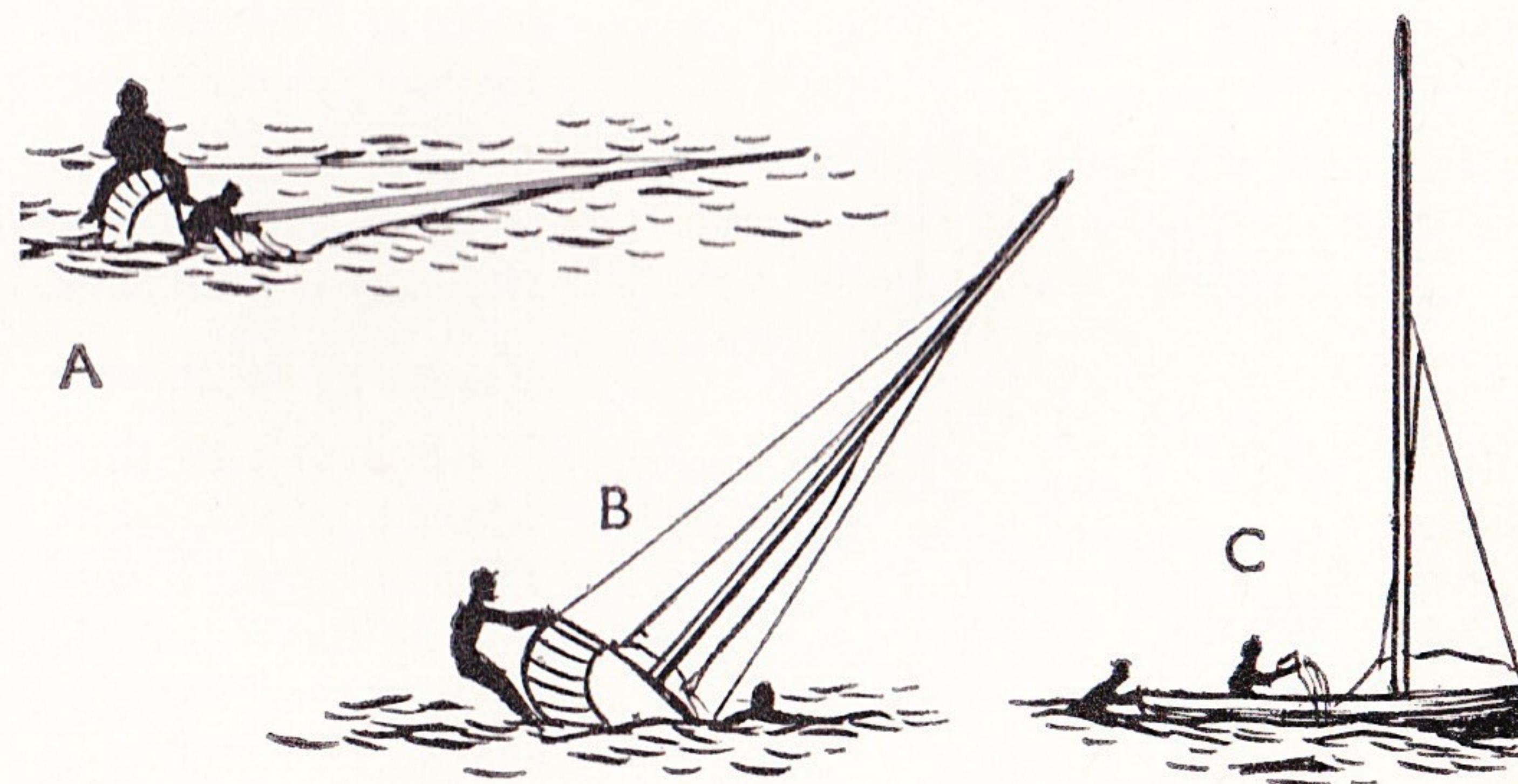
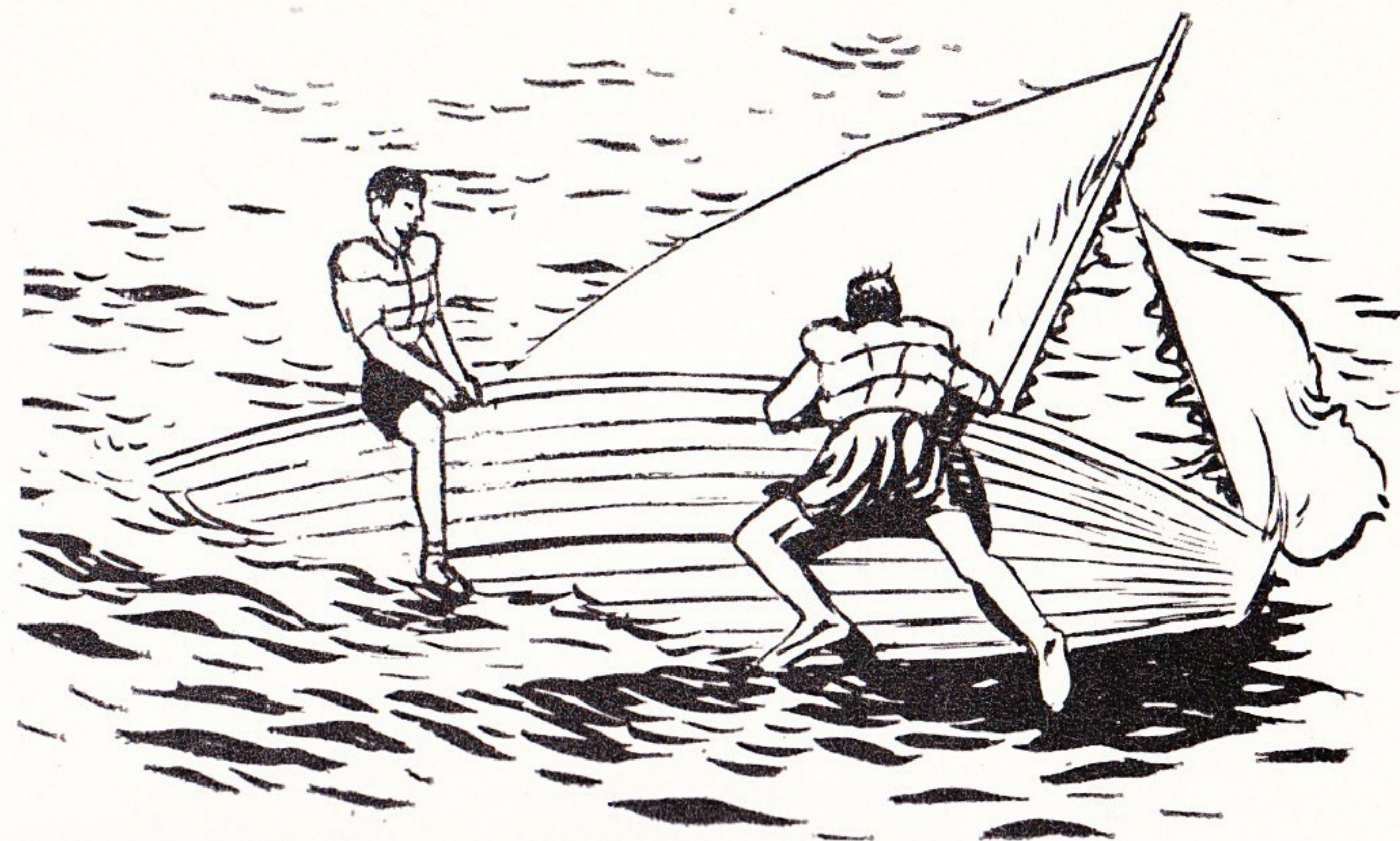

Fig. 45. Capsized dinghy. A. Get mainsail down; B. Lever boat upright; C. Bail out, and climb in over stern or swim ashore with boat

## Man Overboard

As quickly as possible throw something that will float to act as a lifebelt, but be careful not to hit the person in the water.

Whatever course is being sailed the quickest way to turn the boat is to gybe, but in strong winds it may be better to tack round although this will take more time. The aim is to bring the boat round head to wind—with no way on—to leeward of victim (see Fig. 46). Pass him a line: mainsheet or jibsheet will do. If the boat is large and stable enough, help him aboard over the stern—not over the side.

In a small dinghy this may not be possible. In this case lower all sail and make a loop in the end of the mainsheet tied with a bowline. With this supporting the victim under his armpits and holding on to the transom, paddle ashore. If when sailing single-handed the helmsman falls overboard, provided the boat has weather helm it should come up slowly into the wind and drift to leeward. He must **not** let go of the boat.

Crew and helmsman should always wear special buoyancy clothing or life jackets (even if they are first class swimmers). At sea, sailing clothing should be a bright and distinctive colour, easily seen at a distance.

After a capsize the hull, sails and spars must be thoroughly washed down with fresh water. Remember to hose through a hollow mast, and check all the gear, particularly the shrouds.

## Returning to shore

Returning to the shore correctly is often more difficult than getting under way. Make sure you come in slowly at a spot clear of other craft.

*With an onshore wind* (Fig. 47A). While well clear, turn head to wind, furl the mainsail and jib too if the wind is strong, then drift ashore under bare poles, or paddle.

*With a wind that is offshore* (Fig. 47B) or blowing *parallel to the shore* (Fig. 47C), speed should be reduced by luffing, and the boat sailed slowly to the shore. The helmsman should now know just how far the boat will proceed when turned into the wind—most modern dinghies will stop instantly. If the water is too shallow to use the plate and rudder, sails must be dropped and the boat paddled to the shore. Do not obstruct the sailing committee's view of the line.

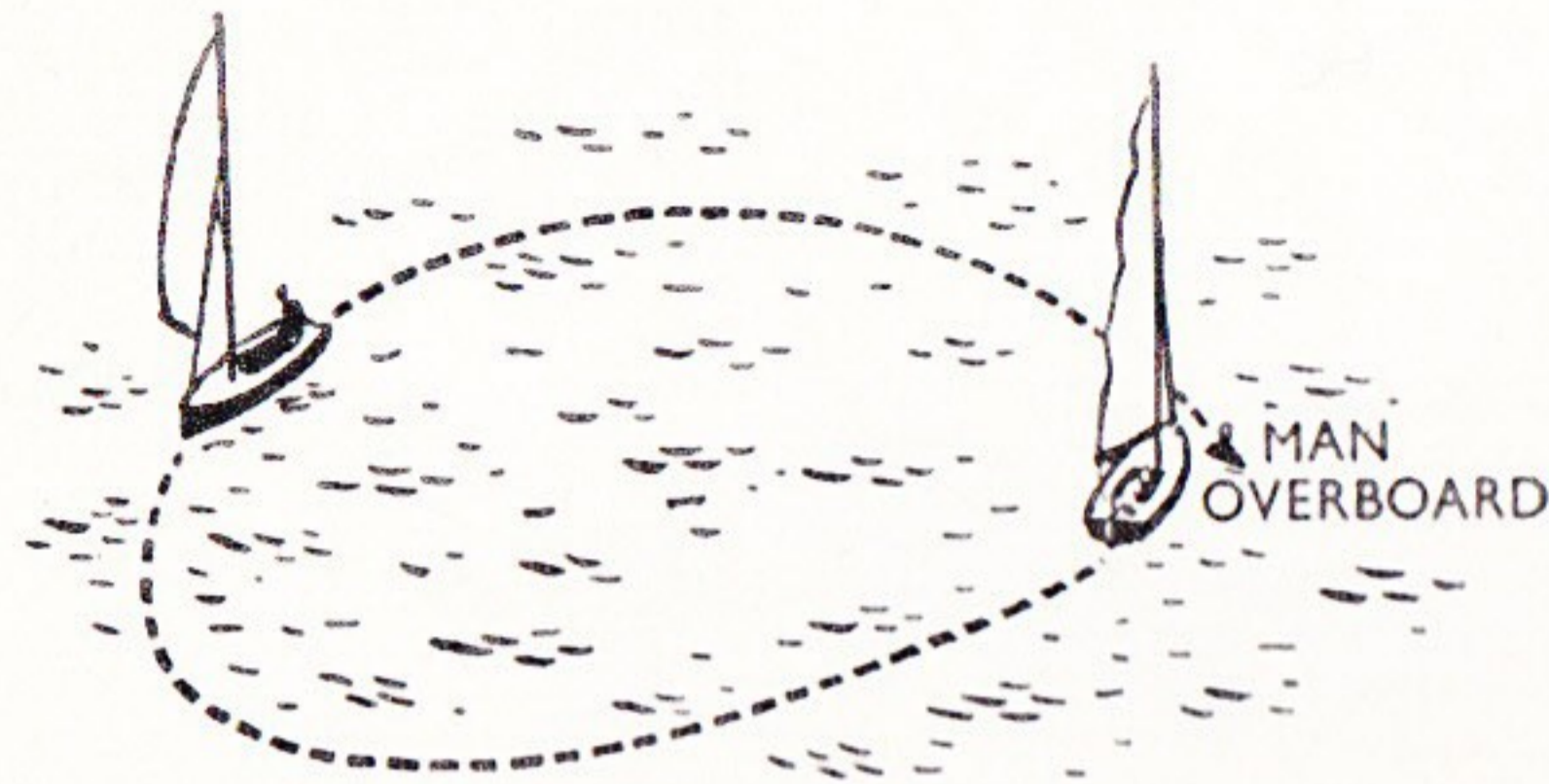

Fig. 46

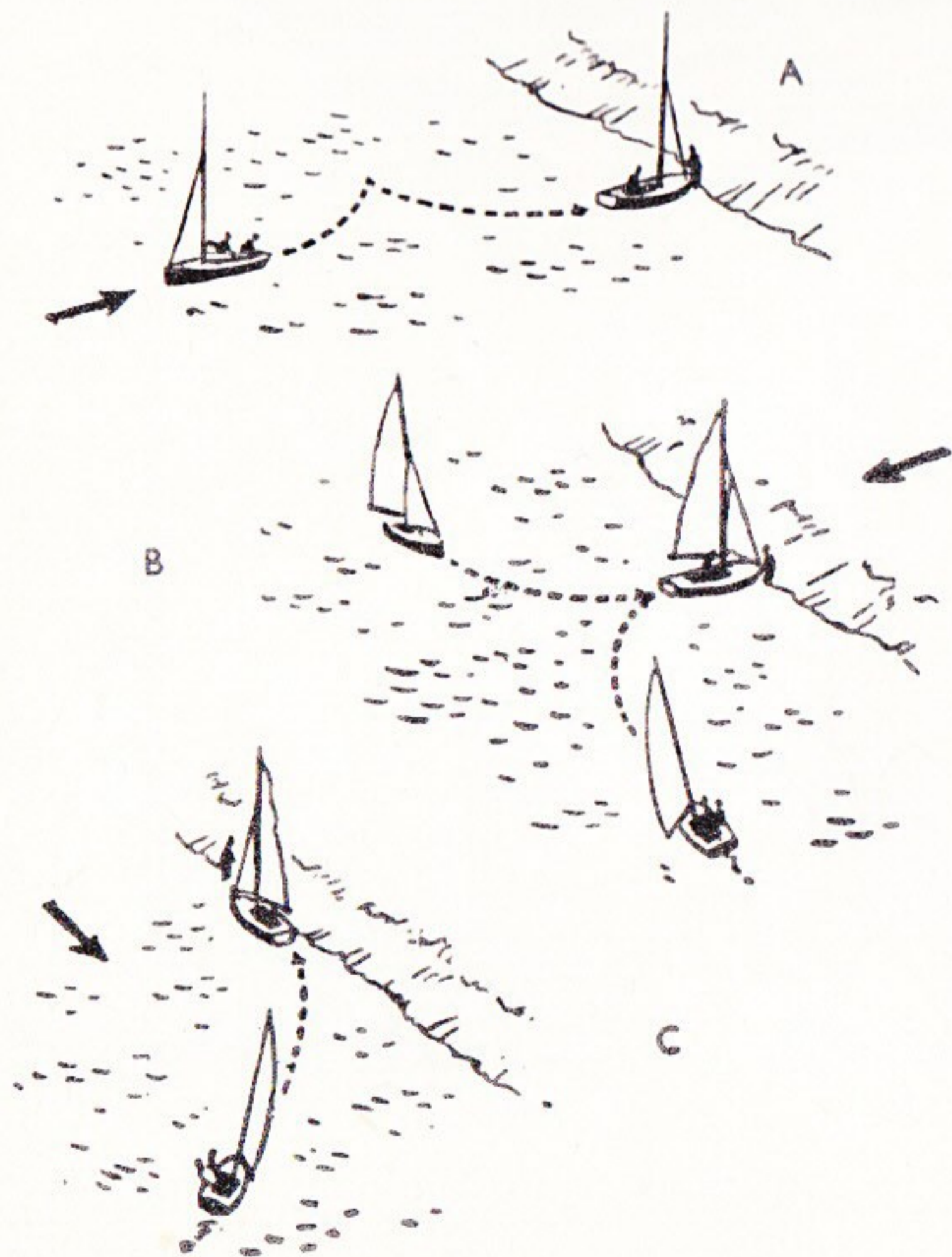

Fig. 47 Returning to shore

# Knots & Hitches

The knots shown on this page will cover all the requirements of a small boat sailor. An efficient knot must be easily and quickly tied, become more secure as the strain on it increases, and be capable of being quickly untied or cast off. The main length of a rope is called the standing part—a loop is called a bight and the short end the free or running end, see illustration below.

RUNNING END

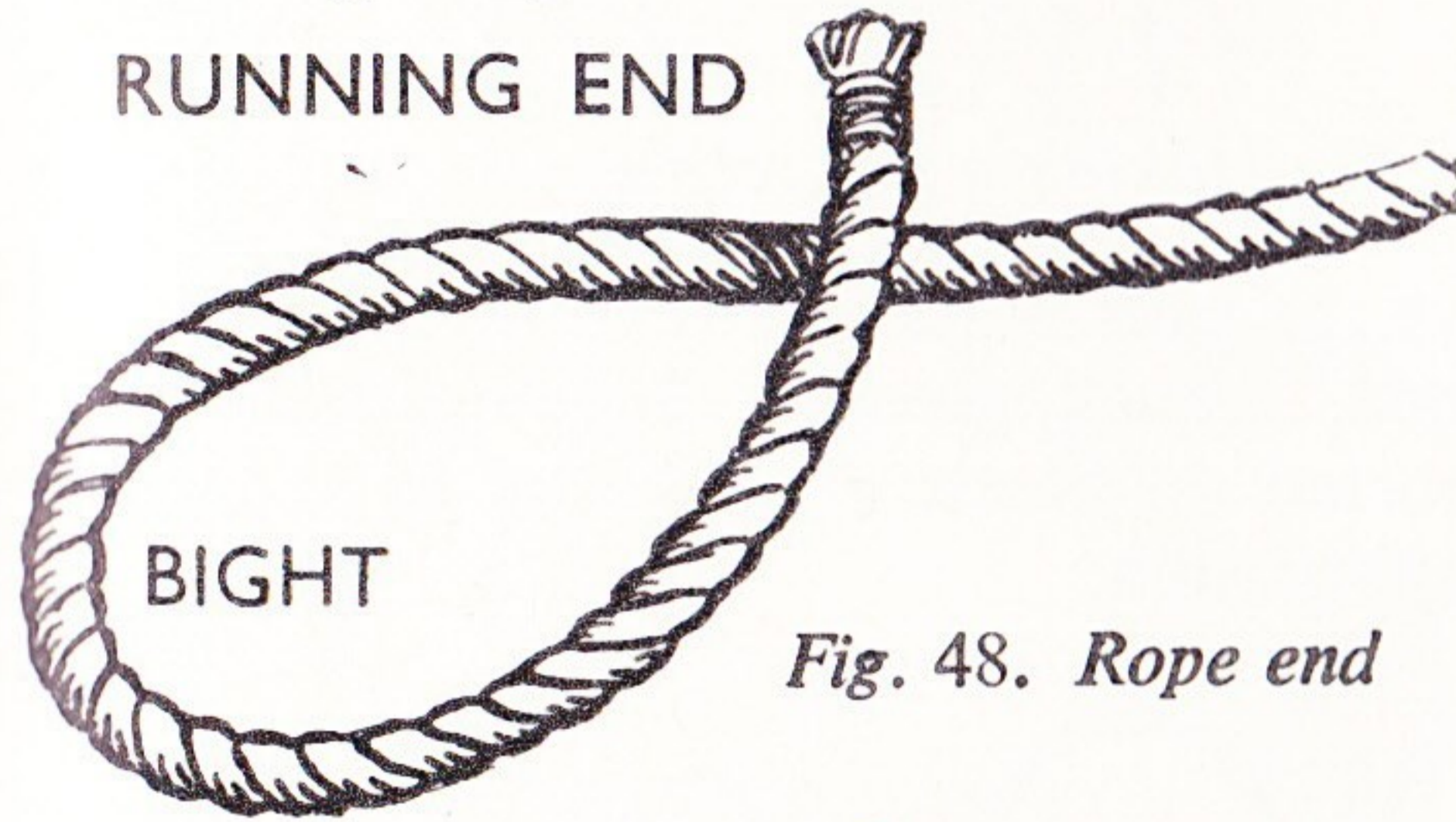

Fig. 48. Rope end

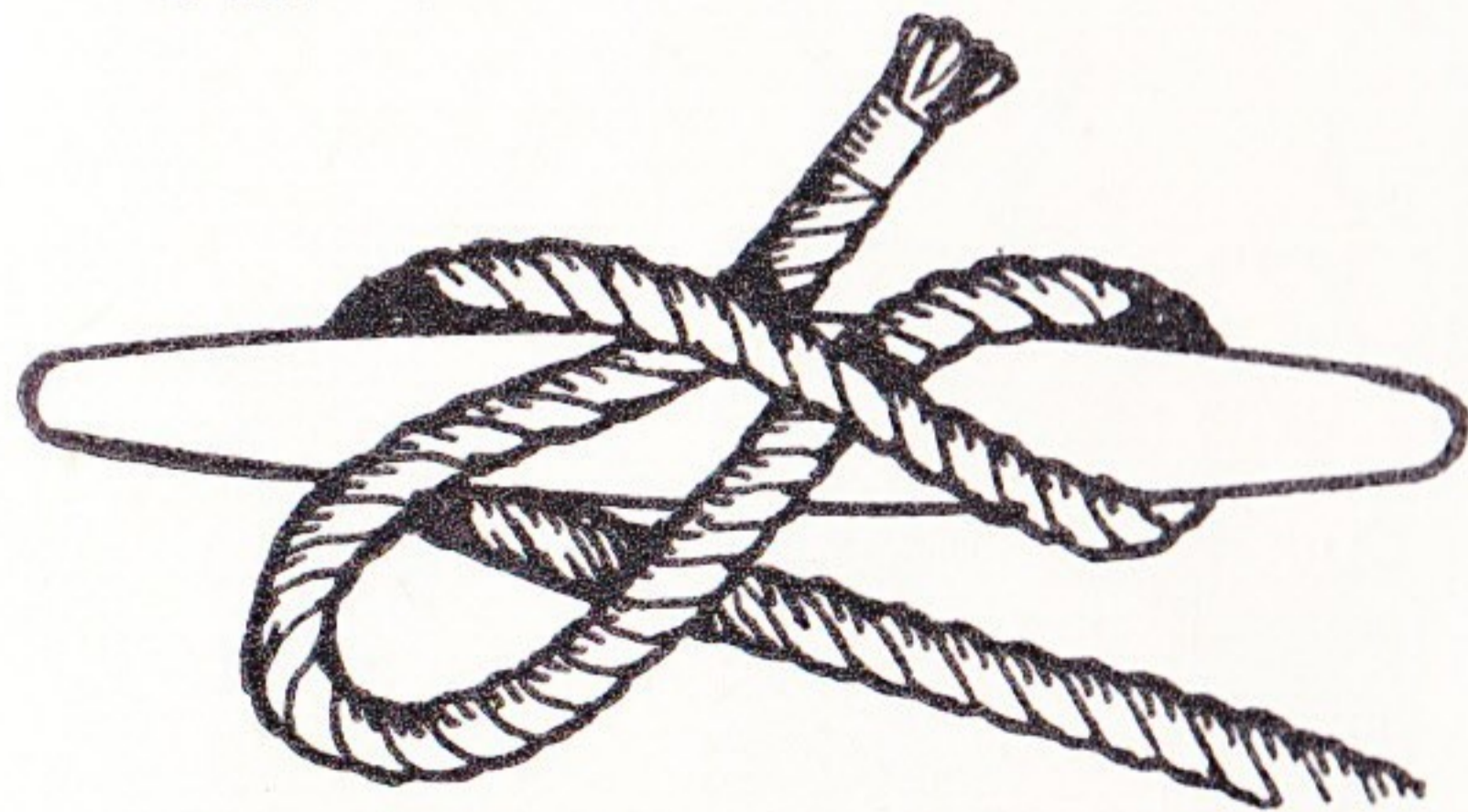

Fig. 49. Slippery Hitch. For temporarily belaying a sheet—a pull will free it instantly. Never make sheets fast in a dinghy.

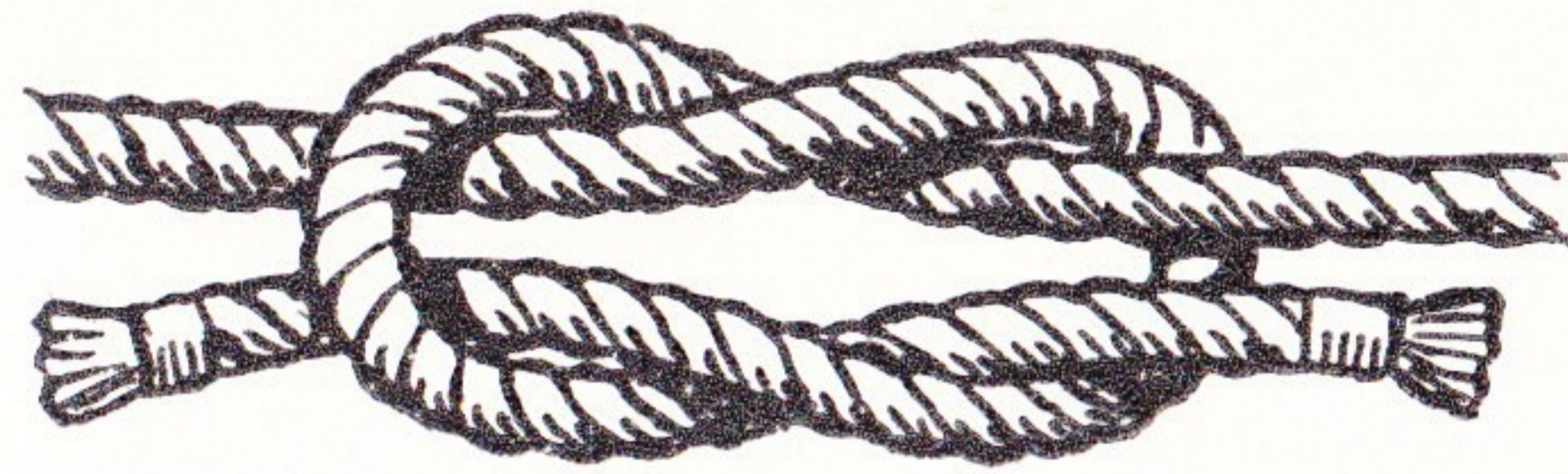

Fig. 50. Reef knot. Used where two ends of a single rope need joining. Do not use to connect two ropes.

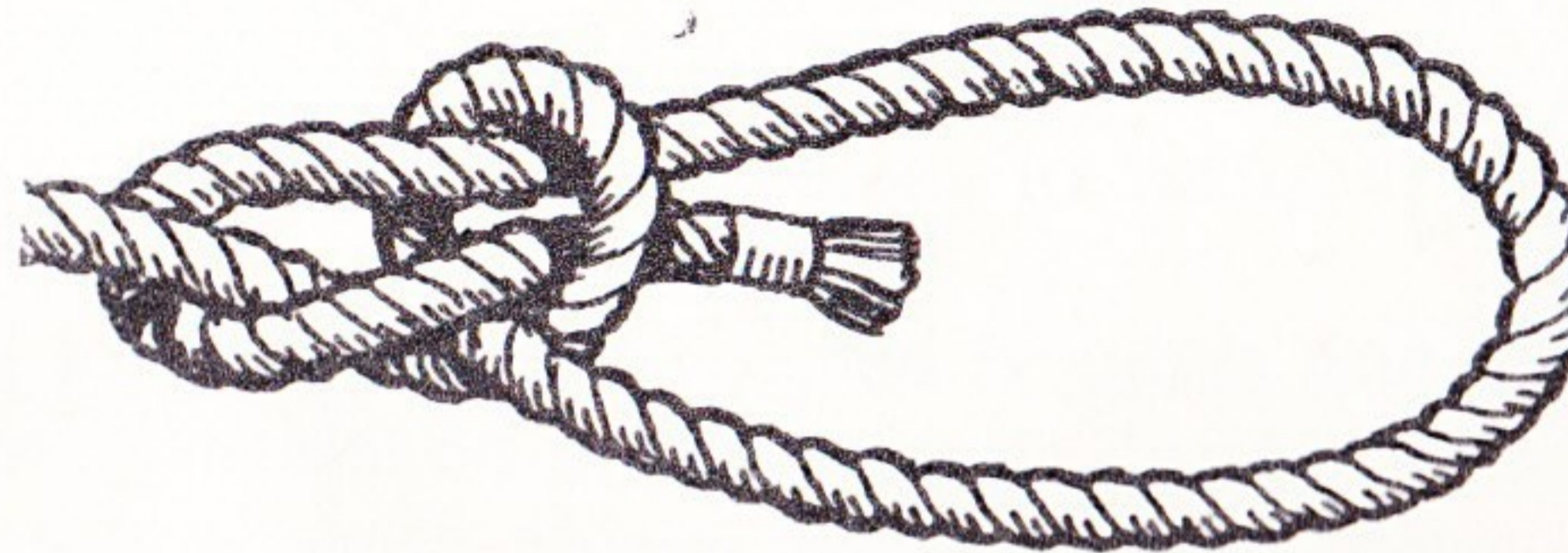

Fig. 51 Bowline. Used for forming a loop in the end of a rope which will not slip but can easily be untied.

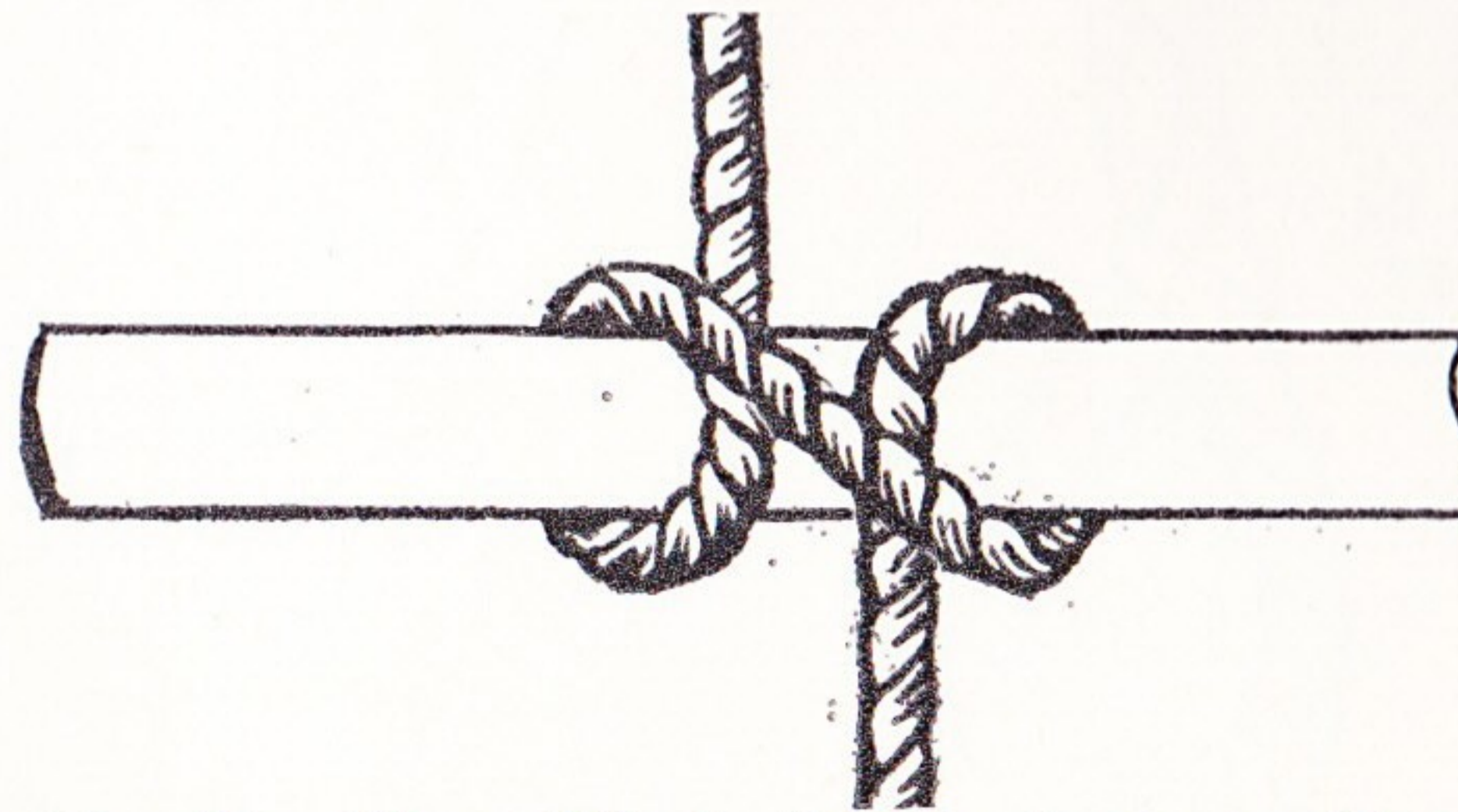

Fig. 52. Clove Hitch. Hitch for attaching a rope to a spar or post.



Fig. 53 Sheet Bend. For tying two ropes of the same size together or attaching a rope to a loop.

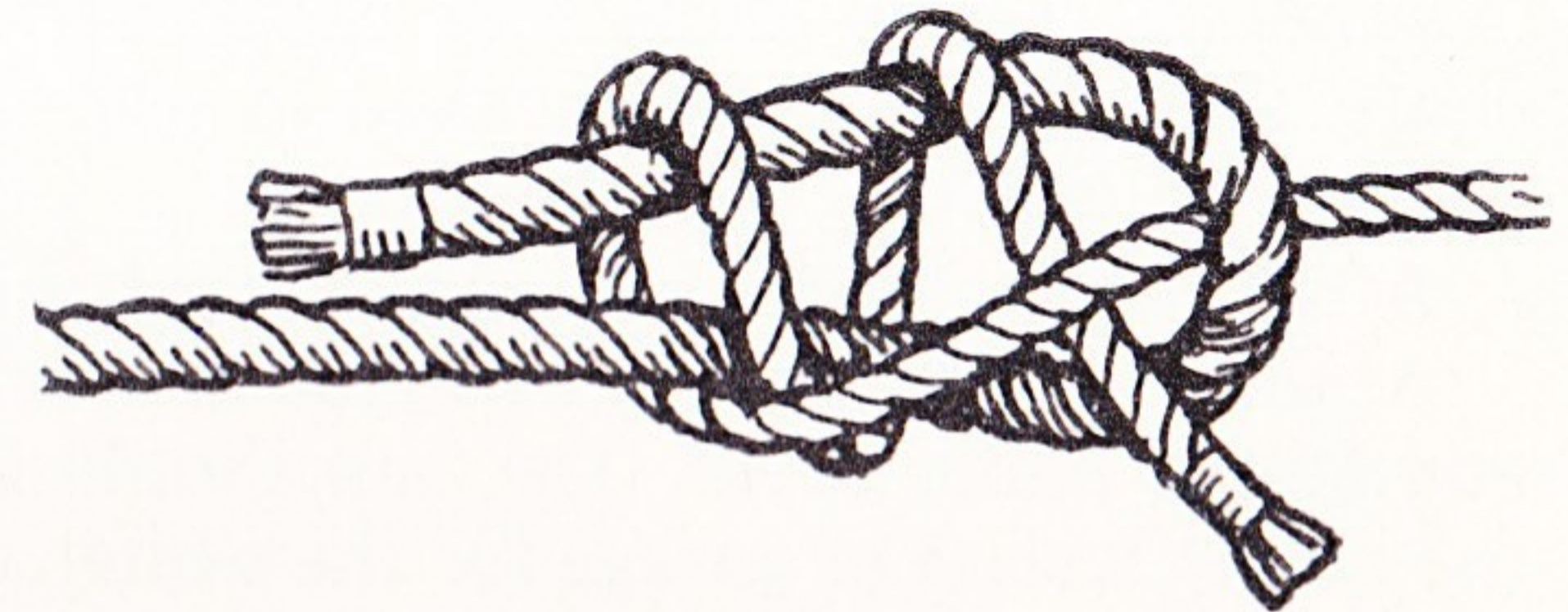

Fig. 54. Double Sheet Bend. The best method of joining two ropes of unequal thickness. Can also be used for attaching rope to an eye splice or ring.

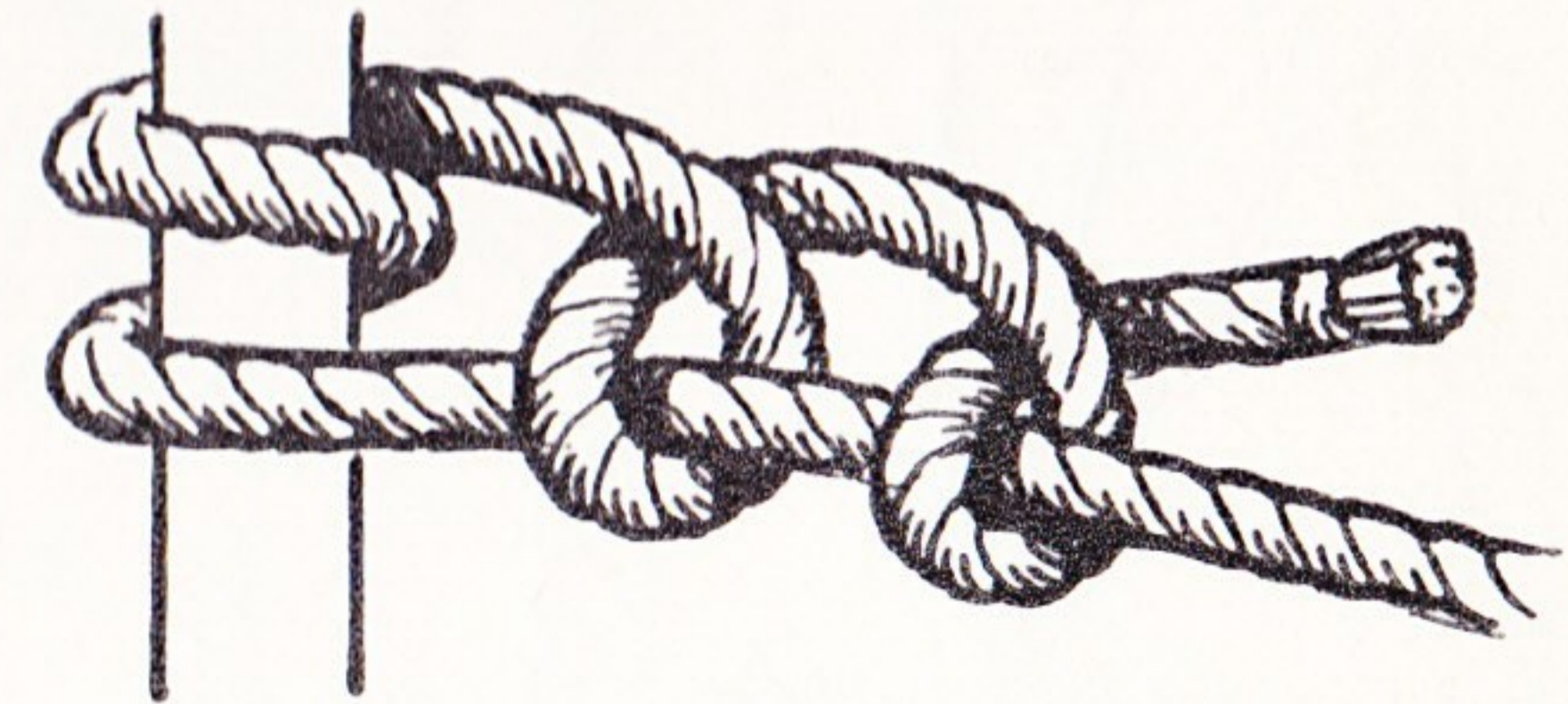

Fig. 55. Round turn and two half hitches. For making fast boat's painter to a post or ring.

# Maintenance

Every owner should carry in the boat a length of line, and a strong pen-knife equipped with a shackle opener and a marline spike. He should also have a few carpentry tools (and some good waterproof adhesive) ashore, for repairs between races.

Sheets and halliards must be overhauled regularly and renewed when they show signs of wear. Prevent rope ends from fraying by whipping with seizing twine against the lay of the rope. Synthetic sheets and ropes may be whipped and the ends heat sealed with a match or hot iron.

Standing rigging should be checked frequently for signs of rust or chafe. Shrouds should be soaked in warm oil at the start of the season, and wiped clean.

After sailing, the hull should be washed down and sponged before covering. Do not leave the sails bundled round the boom. At the end of the season when the boat is to be 'laid up', all gear should be removed, washed, cleaned, greased where necessary and stored under cover. The hull should be washed down, turned upside down and supported on blocks. It is better to keep the hull in a shed or garage for the winter, but if left in the open it should be covered with a tarpaulin.

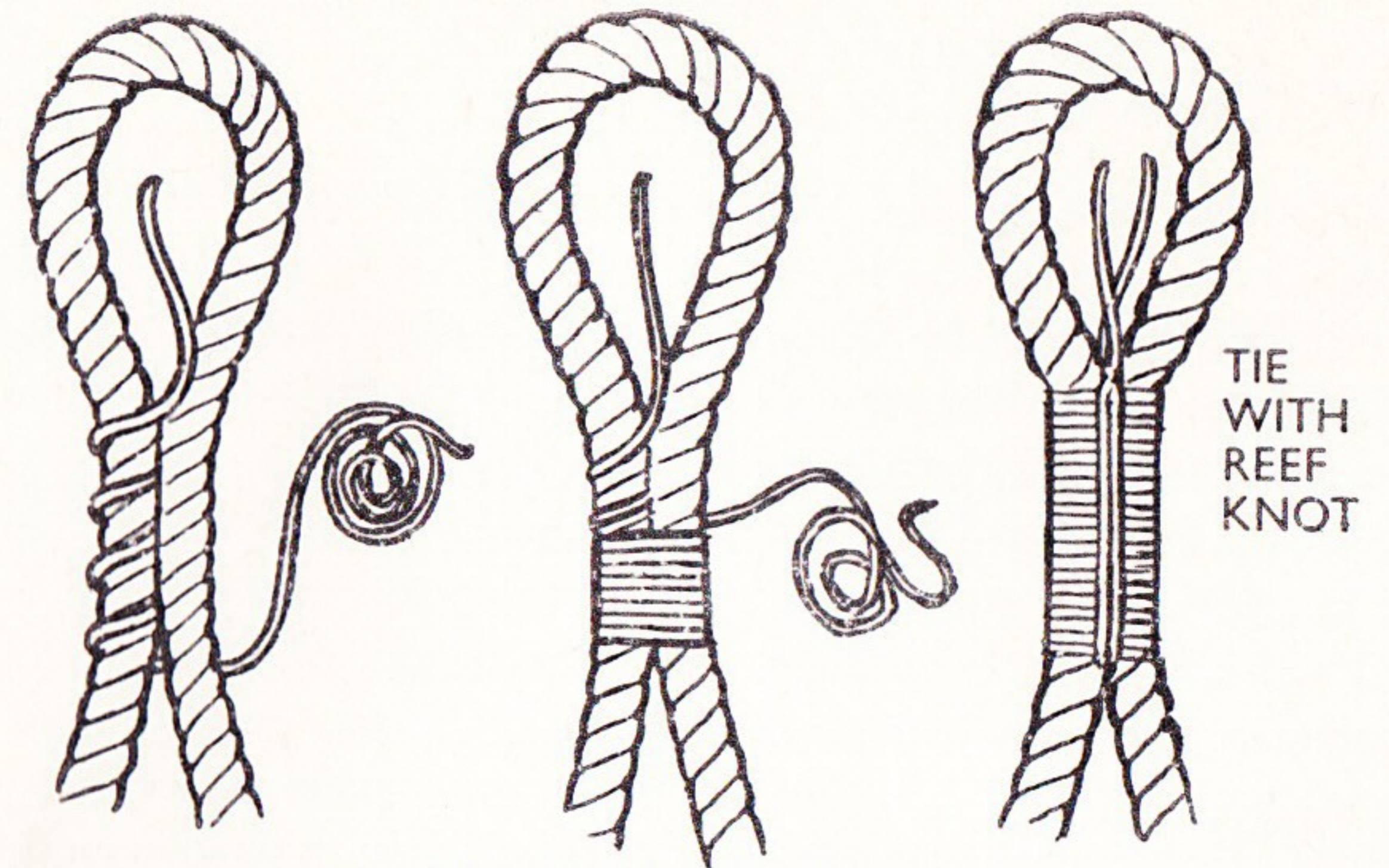

Fig. 57 Making a flat seizing

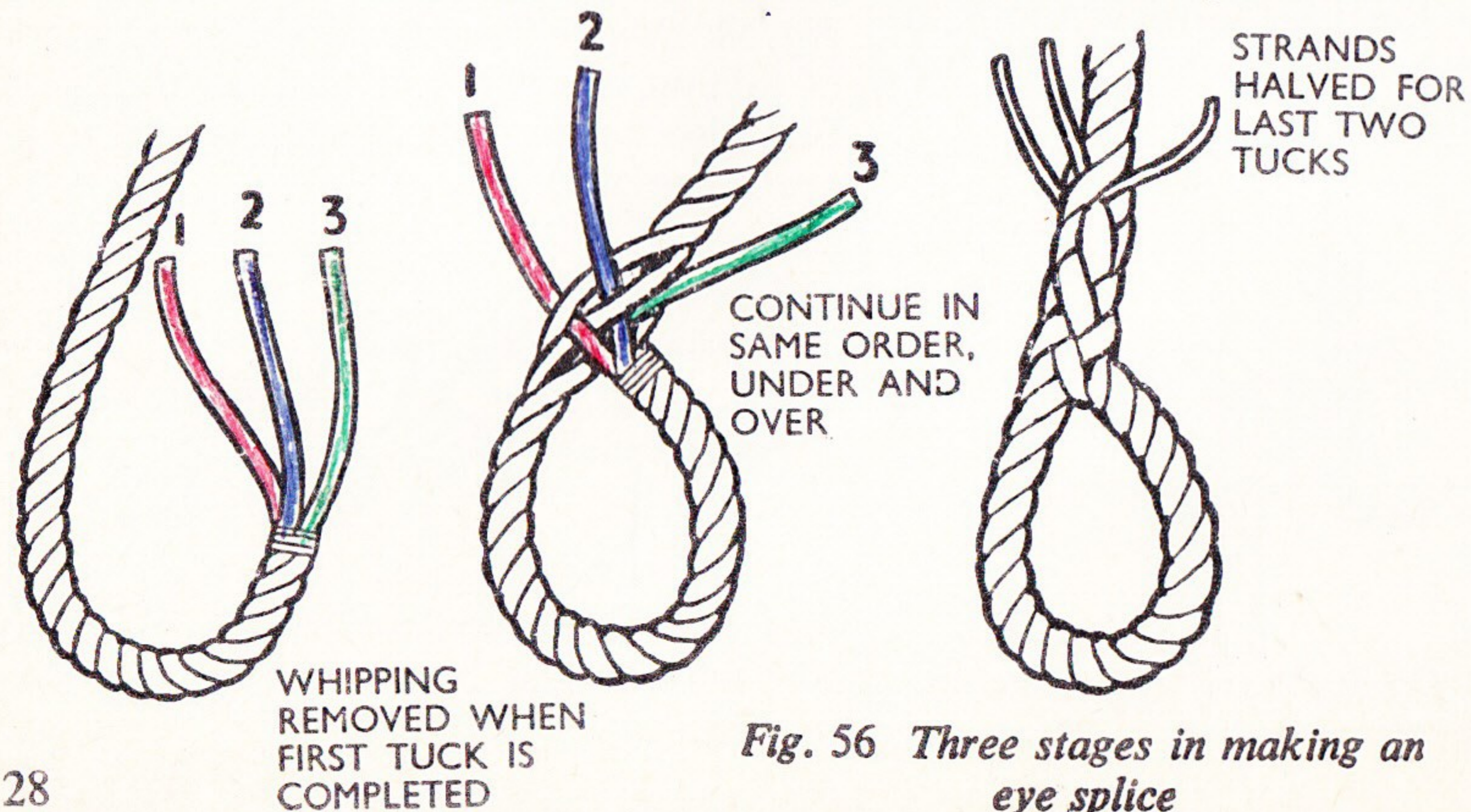

Fig. 56 Three stages in making an eye splice

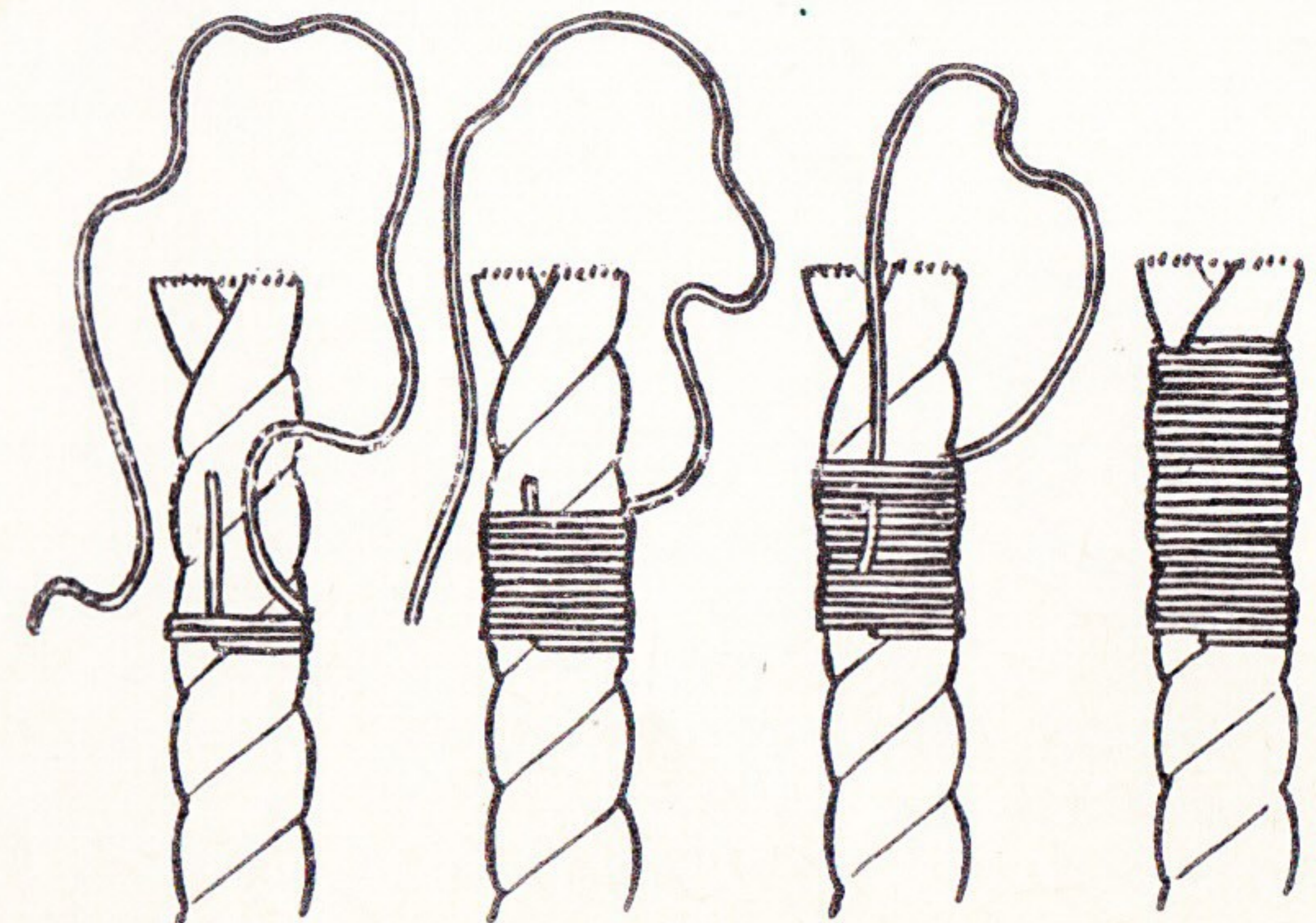
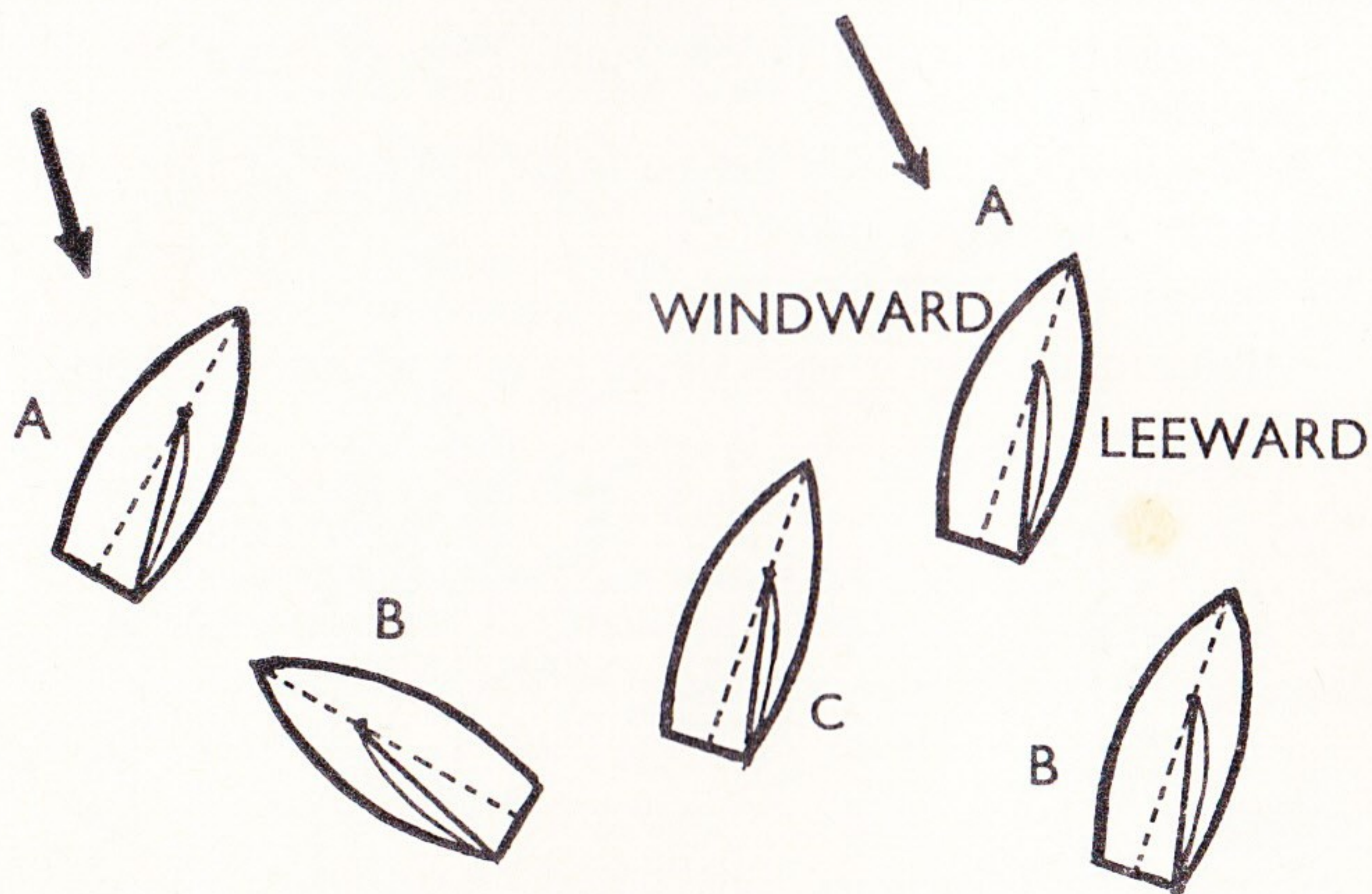

Fig. 58 Whipping a rope end

# Some Racing Rules

The I.Y.R.U. racing rules are referred to in the following explanations. These are framed to avoid collision and to state which yacht has right of way under differing circumstances. Figs. 59-63 illustrate the main terms used in the rules, some of which are explained on the following pages.



*Fig. 59 A is on port tack (wind is on port side). B is on starboard tack (wind is on starboard side)*

*Fig. 60 B is leeward of A. C is windward of A. When viewed from A, B is the leeward yacht and C is the windward yacht, but only when the yachts overlap and are on same tack*

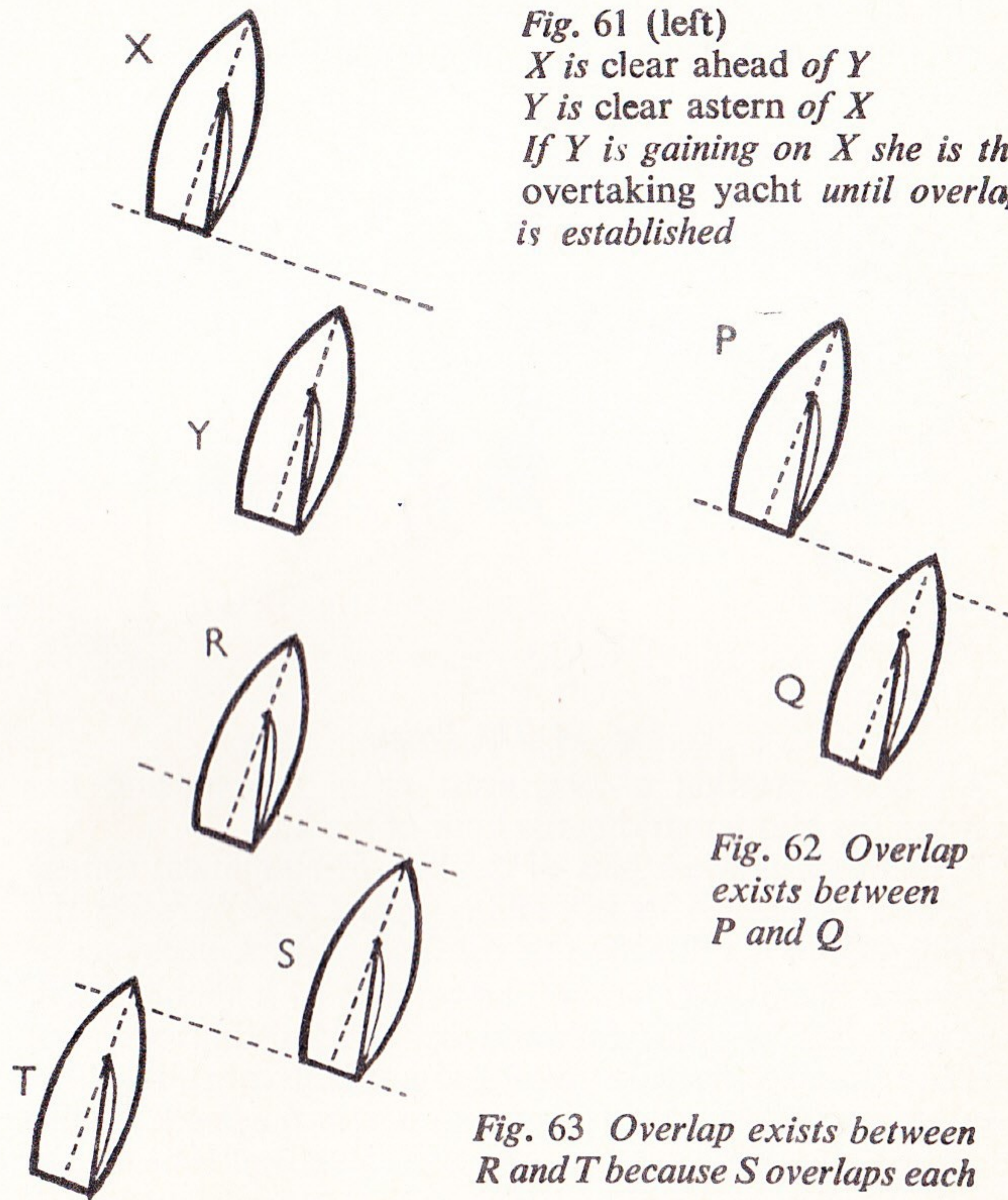

*Fig. 61 (left)  
X is clear ahead of Y  
Y is clear astern of X  
If Y is gaining on X she is the overtaking yacht until overlap is established*

*Fig. 62 Overlap exists between P and Q*

*Fig. 63 Overlap exists between R and T because S overlaps each*

The sailing instructions issued by the club should give the procedure for the day in detail particularly where there is any deviation from practice laid down by the R.Y.A.

The starting line is indicated by posts on shore and by mark buoys, or a transit post on the committee boat.

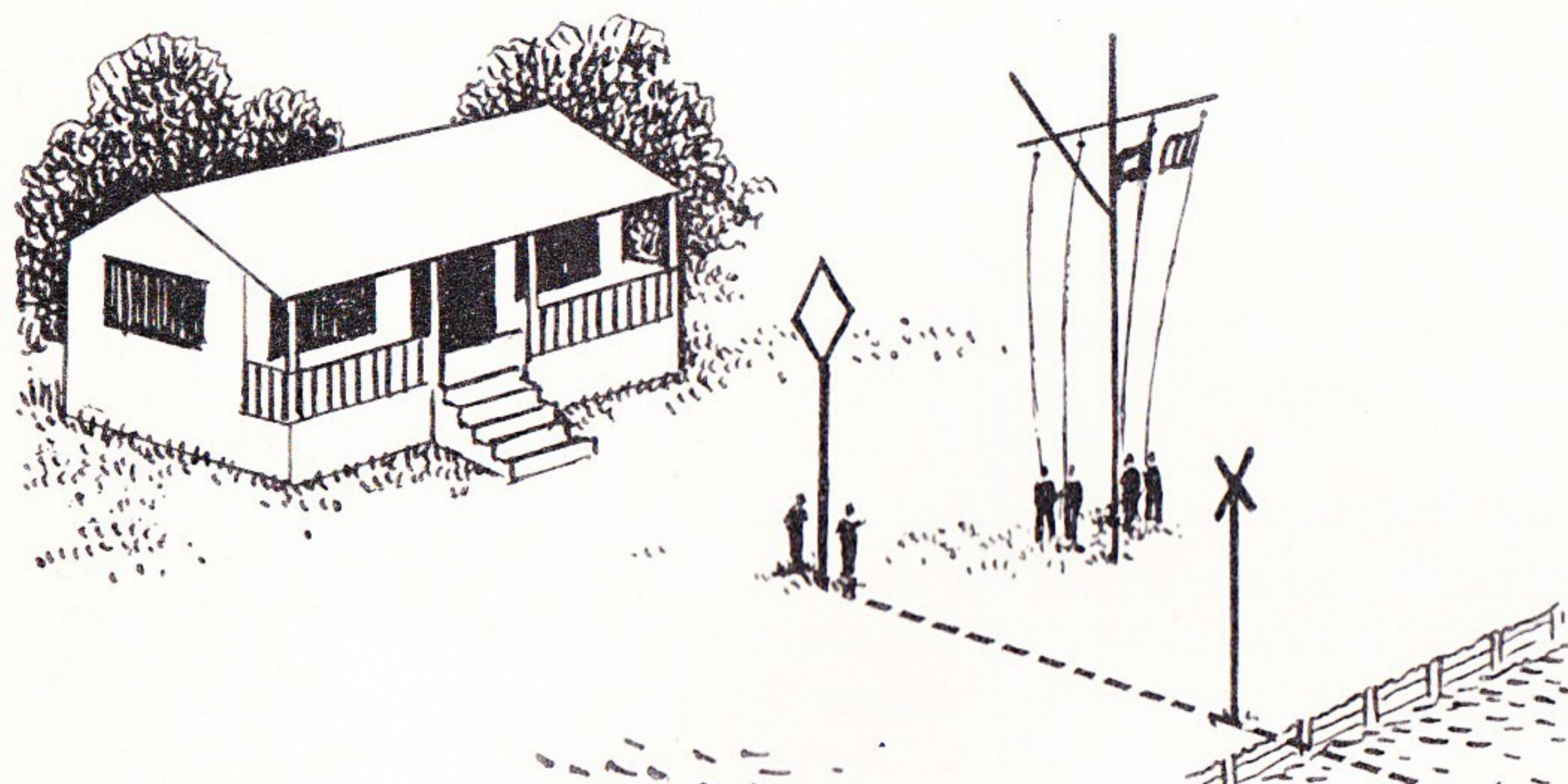
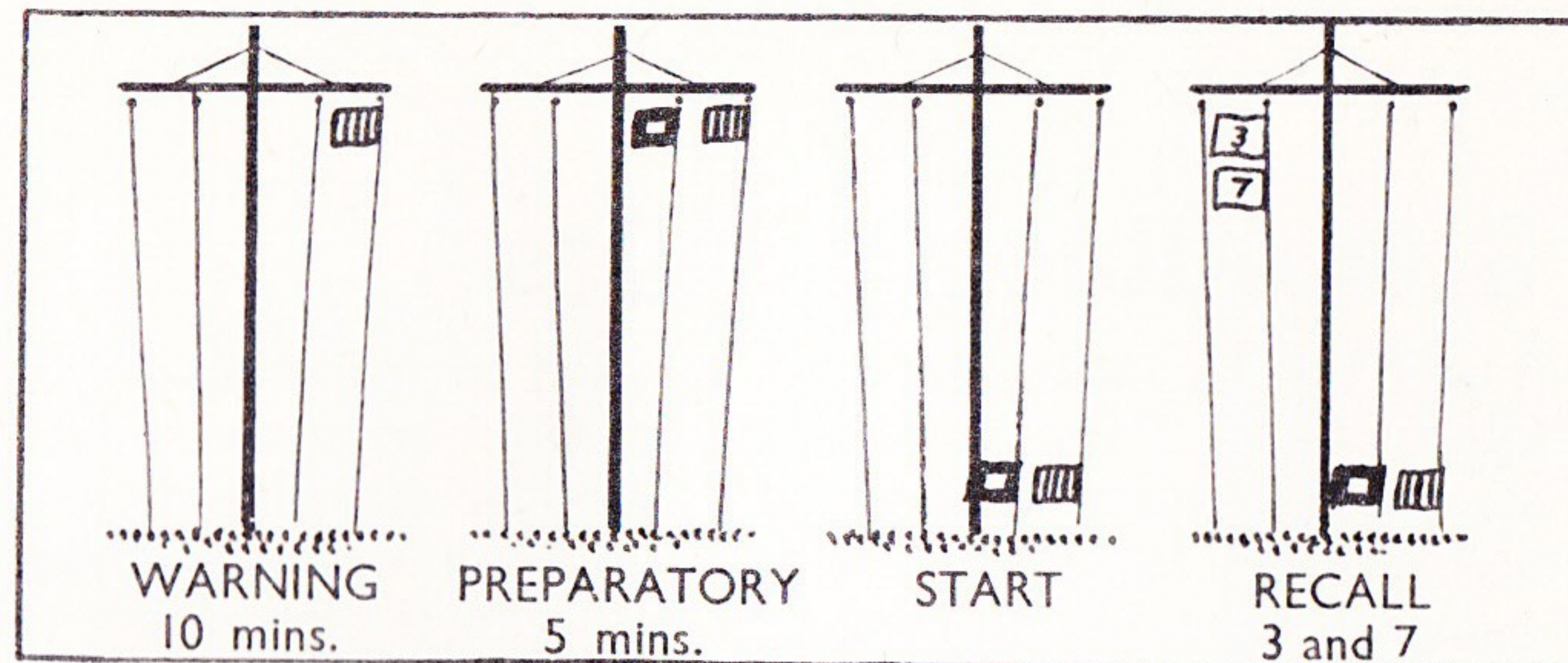

Fig. 64 The Start

All boats starting a race must cross the starting line between the buoys marking the limit of the line.

A yacht starts when part of the hull or equipment (unless otherwise prescribed in the sailing instructions) crosses the starting line in the direction of the first mark. A yacht on or across the line at the start will be recalled by a sound signal, probably bell or gun, followed by the hoisting of recall number. In large fleets of small boats it is usual to recall by loud hailer. If many yachts are on or across the line, a double sound signal is made and a general recall signal is hoisted to recall all yachts for a restart. This flag is the 'First Substitute'.



*Warning:* 10 minutes before start. Flag or distinctive signal denoting class of race.

*Preparatory:* 5 minutes before start. 'P' flag of international code or distinctive signal.

*Start:* Both signals lowered.

Attention is drawn to each signal by gun, whistle or other sound.

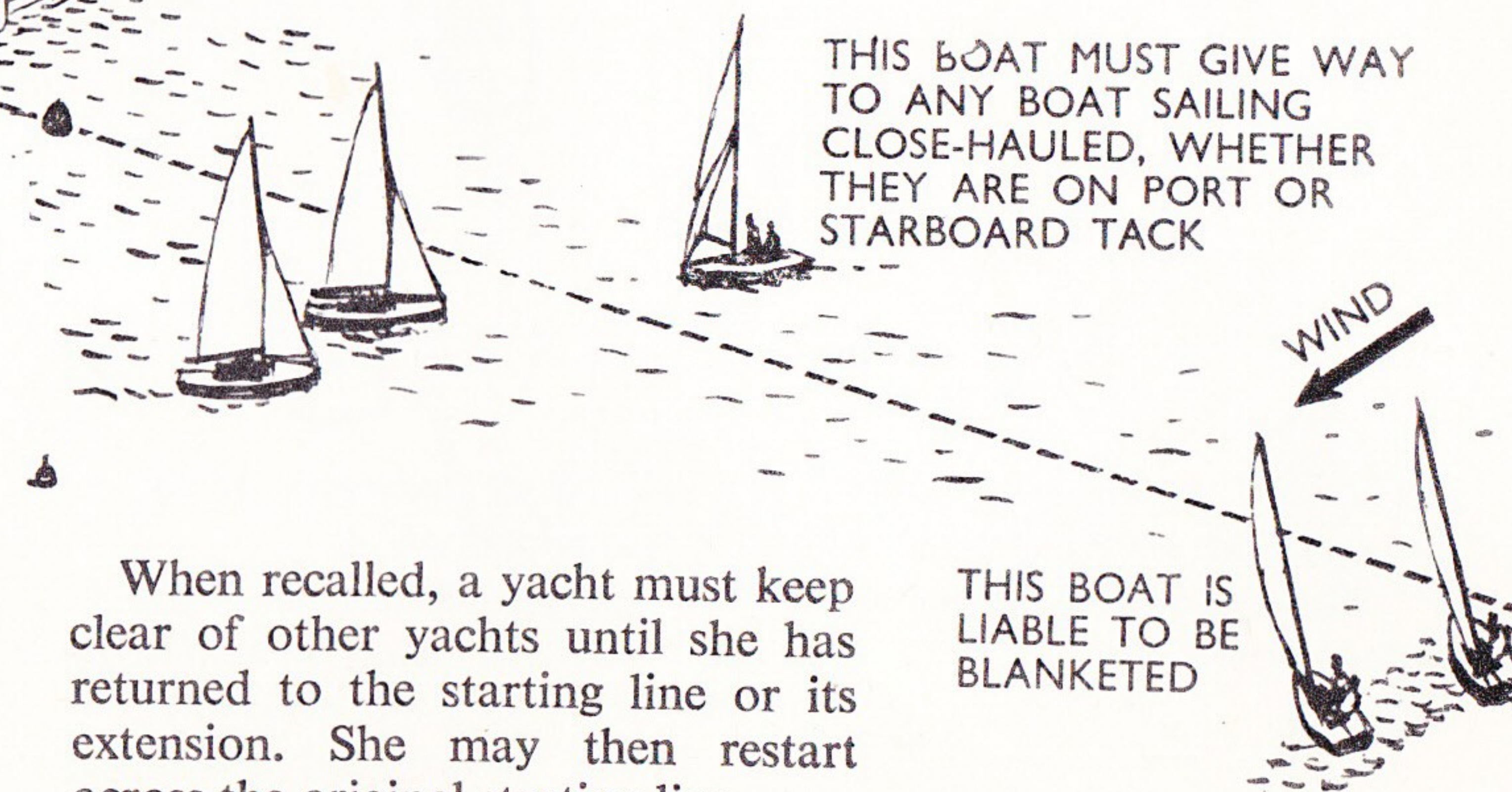

When recalled, a yacht must keep clear of other yachts until she has returned to the starting line or its extension. She may then restart across the original starting line.

From the five minute gun the racing rules come into operation. In Fig. 65, boat F on port tack must give way to E on starboard tack.

Until the starting line is crossed, an overtaking boat must keep clear when overtaking to windward. In Fig. 65, until line is crossed, C must keep clear of D. If the overtaken boat chooses to luff, the overtaking boat must keep out of the way. Between the five minute gun and the starting signal, a yacht clear ahead or a leeward yacht may alter course only gradually so that the overtaking boat can easily respond.

After the starting signal, the boat with right-of-way must sail a course consistent with crossing the line in the direction of the first mark, that is, it must not luff. In Fig. 65, D must not luff after the starting signal has been given. After crossing the starting line, if overtaking conditions still permit the overtaken boat to luff, she may do so.

A yacht which does not follow the rule to keep out of the way can be disqualified whether a collision has resulted or not.

If a right-of-way yacht has to change course to avoid a collision she should immediately protest, but if a serious collision takes place, the right-of-way yacht may also be disqualified.

It is safer to give a hail whenever the opposing yacht may not be clear of your own intentions.

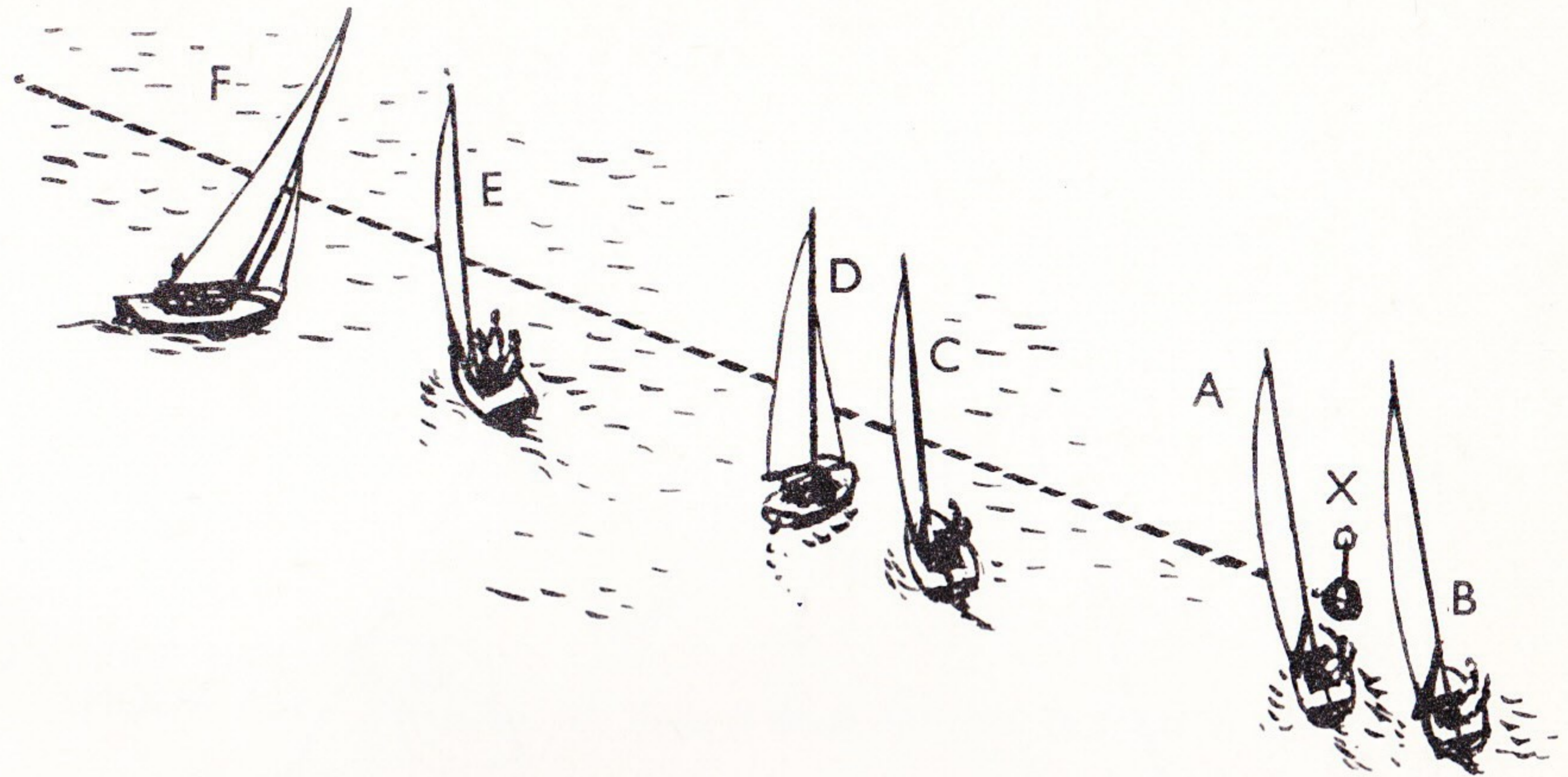

*Fig. 65 Approaching the starting line*

If a yacht continues in the race, even though protests have been made against her, all other competitors must treat her as still taking part in the race and observe all the rules with respect to her.

If X were a mark in the course, and not a mark on the starting line, A would have to give room for B to pass between her and the mark. However, A is making a good start on starboard tack at the windward end of the line and does not have to give B room.

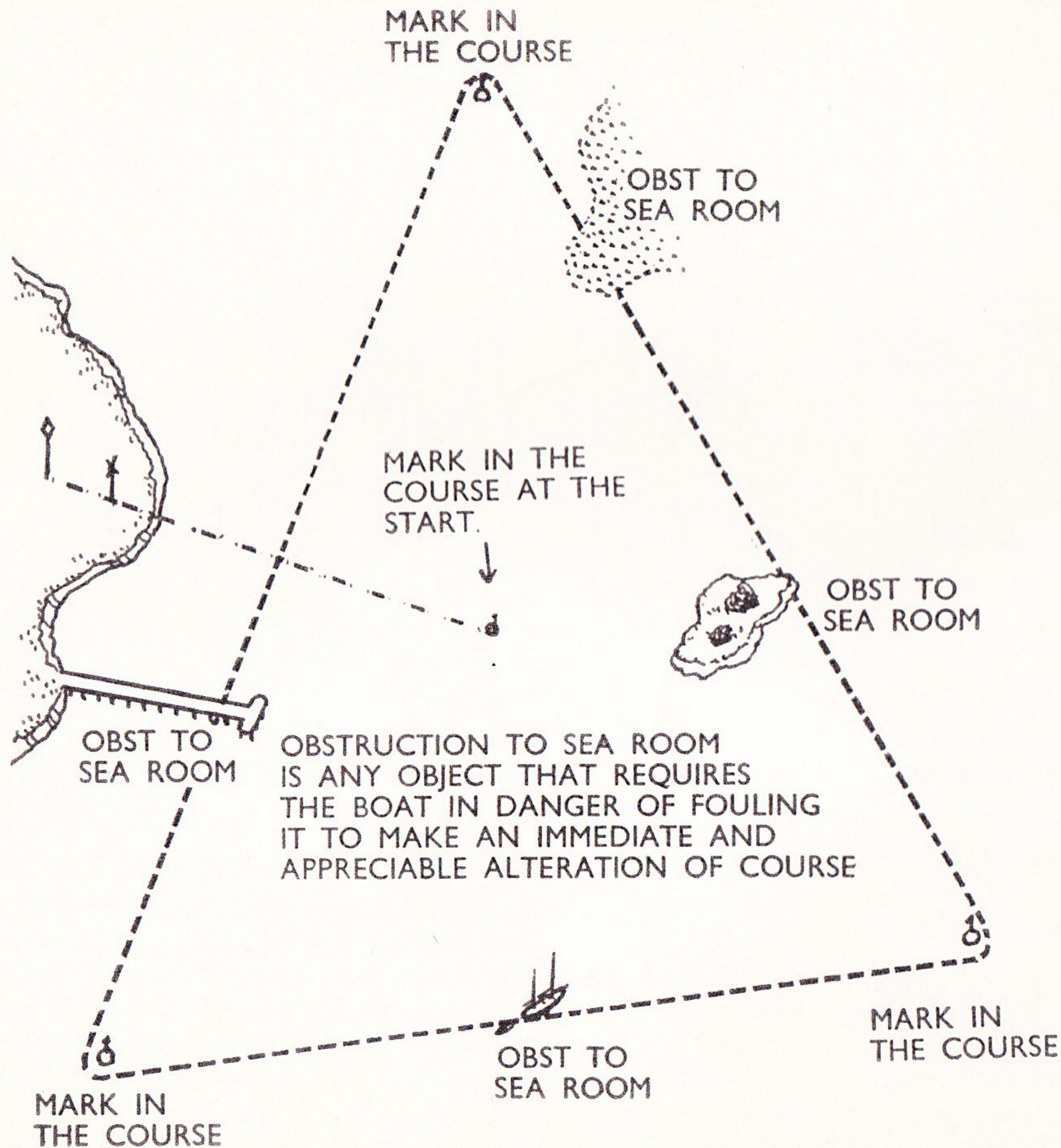

### Rounding a mark

If two yachts overlap the outside yacht must give room at the mark to the inside yacht, but the yacht clear astern must establish her overlap before the yacht clear ahead is within two overall lengths of the mark.

Yacht clear ahead does not need to give room until an overlap is established (to be proved by inside yacht).

Outside yacht to leeward that already has the right to luff, may luff an inside windward yacht to the wrong side of the mark (but she must also sail past wrong side of mark herself).

Yacht clear ahead must only tack when this can be done clear of the yacht astern, Fig. 67.

### Exception at starting line

Leeward yacht does not need to give room to windward yacht on same tack to pass leeward of starting mark; but after the start signal she must not deprive the windward yacht of room by sailing above the mark or above close hauled.

*Fig. 66 Marks and obstructions on the course*

**On opposite tacks, Fig. 68**

Yacht on port tack must keep clear of yacht on starboard tack.

**On same tack**

Windward yacht must keep clear of leeward yacht.

Overtaking yacht must keep clear and if overtaking leeward of another yacht must allow room and opportunity to enable this yacht to keep clear (as the windward yacht).

**Tacking and Gybing**

A yacht tacking or gybing must keep clear of one on a tack. If a yacht is tacking or gybing into an advantageous position it must do so far enough away from a yacht on a tack to enable the latter to maintain her course.

A yacht must not tack when a collision may occur due to another yacht being unable to keep clear.

If two yachts tack or gybe at the same time the one on the other's port side must keep clear of the other.

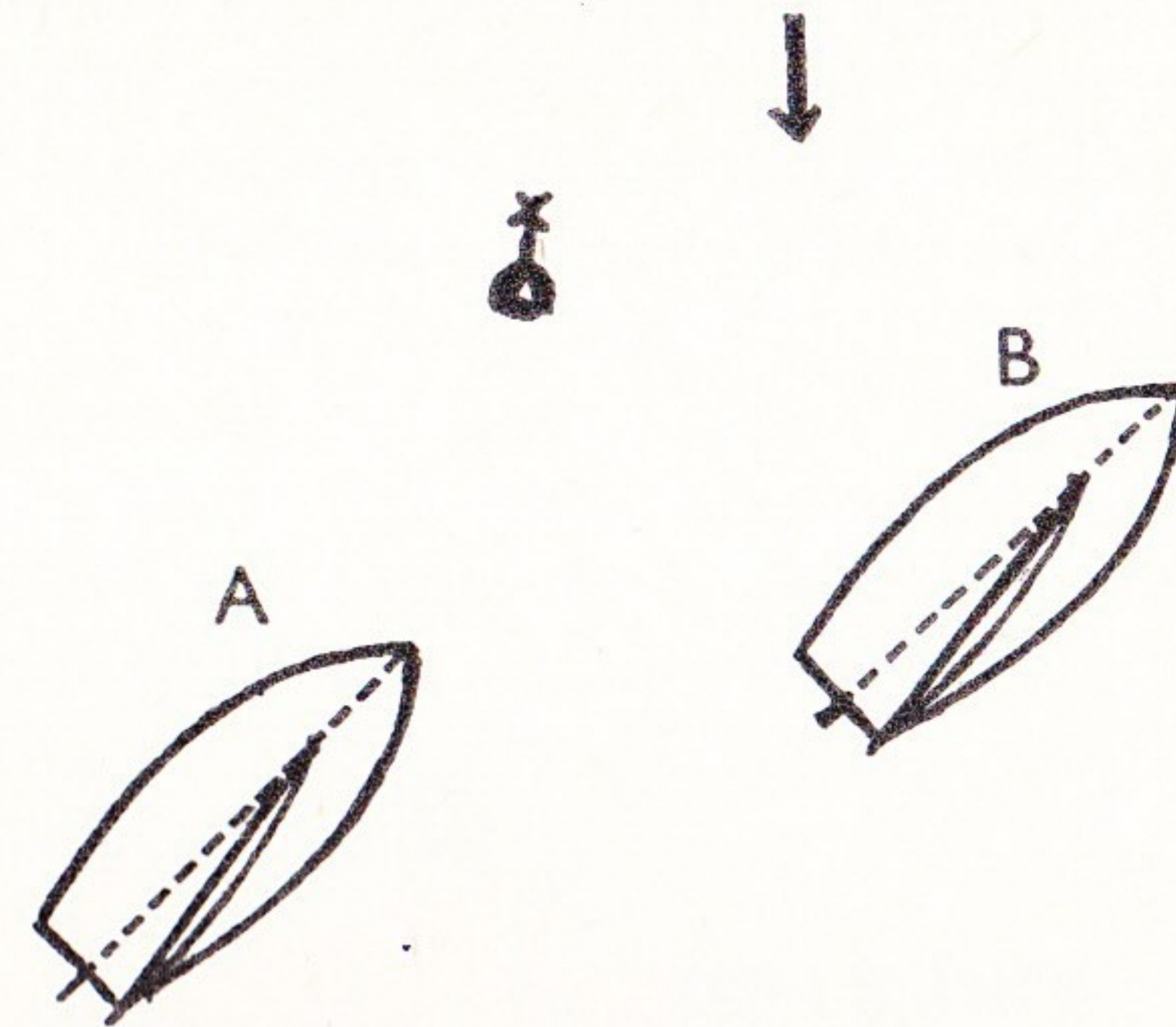

*Fig. 67 Boat B must not tack in front of boat A*

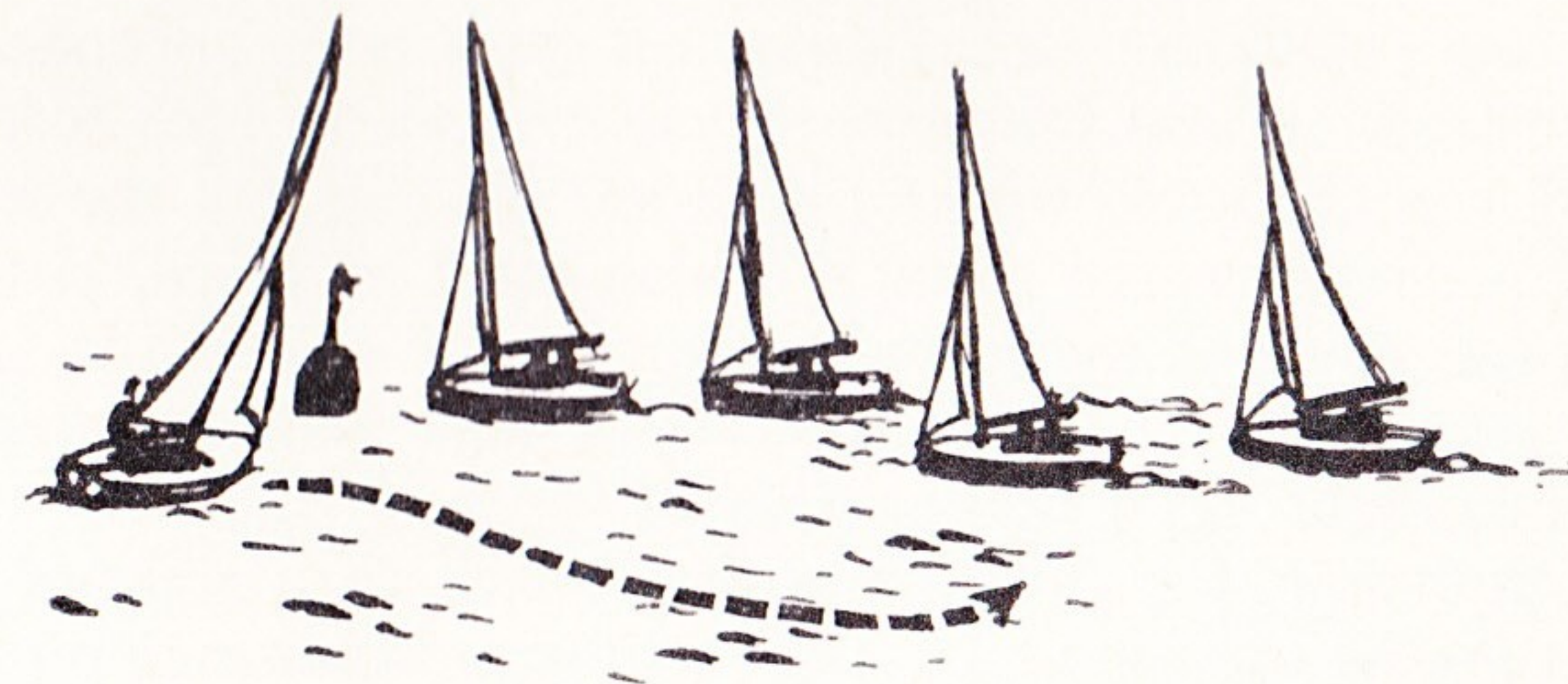

*Fig. 68 Vessels on starboard tack have right-of-way*

### On same tack — luffing, Fig. 69

A yacht may luff a yacht clear astern or a windward yacht, until helmsman of windward yacht comes abreast of the mainmast of the leeward yacht when the leeward yacht must not then sail above her proper course while that overlap continues to exist. (Yachts must be within two yacht lengths of each other. Windward yacht must hail leeward yacht when 'mast abeam'. A yacht must only luff when she is in the correct position with respect to all yachts likely to be affected.)

There are some conditions under which the leeward yacht may not luff—for further details refer to the I.Y.R.U. racing rules (Rule 38).

### On same tack — bearing away

A yacht shall keep on her proper course when within three lengths of a leeward yacht or of a yacht clear astern intending to pass to leeward.

### Close-hauled — approaching an obstruction

If two yachts are close-hauled on same tack approaching an obstruction and the leeward yacht needs to tack to clear it and cannot do so without collision she can hail the windward yacht for room to tack, which must be given, but she must not hail and tack simultaneously.

A yacht clear ahead which cannot tack without affecting another yacht has a similar right to room.

If, however, the obstruction is a mark or a right-of-way yacht on the opposite tack, the yacht to leeward may not hail for room to tack if the yacht to windward can fetch the obstruction (Fig. 70).

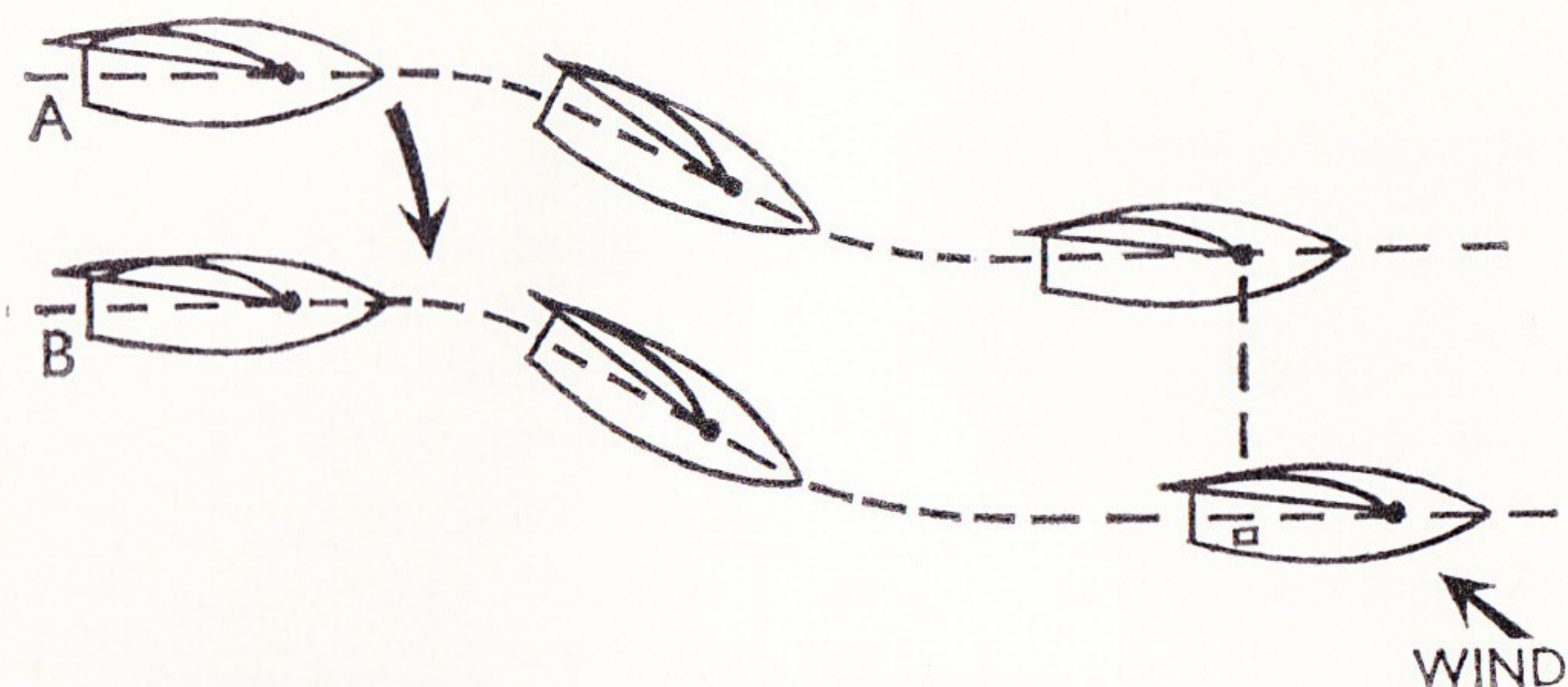

Fig. 69 Boat B must respond to a luff from the leeward boat until the helmsman in B comes abreast of A's mast.

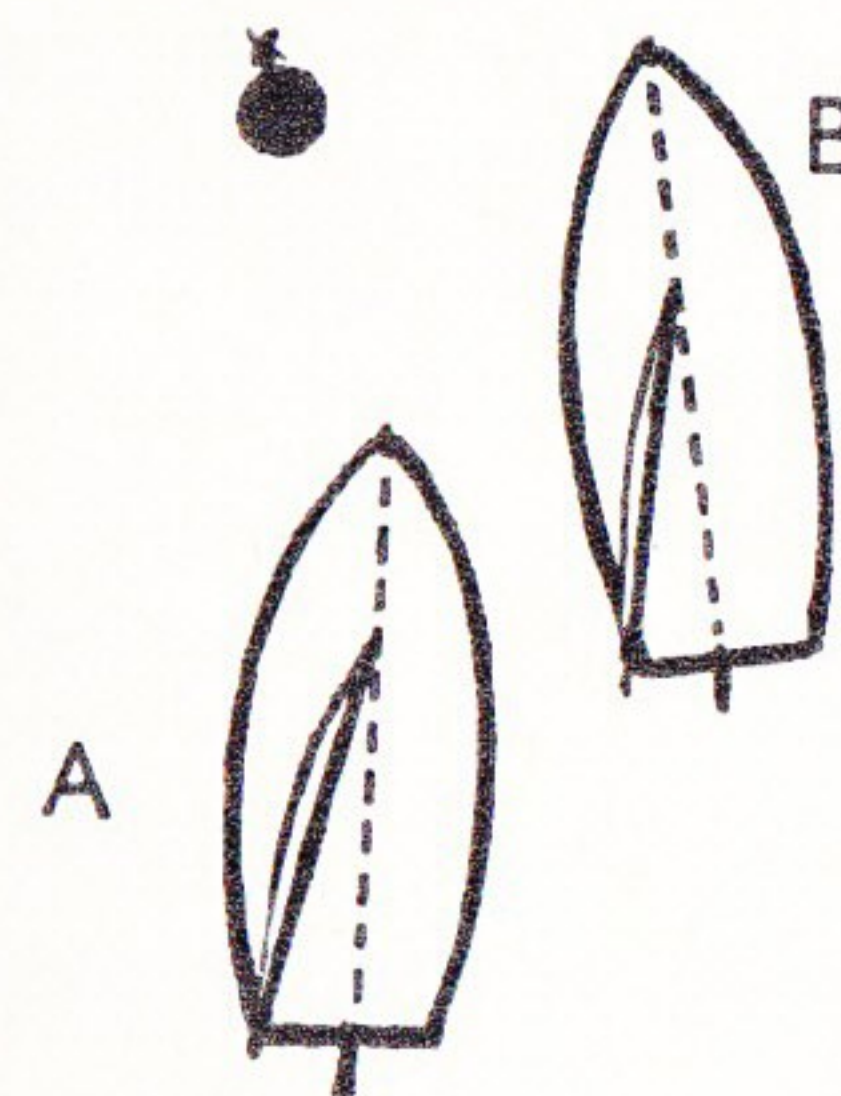

Fig. 70 If boat B can round the mark on this tack, A cannot call for room.

### Misleading or baulking

When one yacht has to keep out of the way of another, the latter must not alter course to prevent her doing so.

A right-of-way yacht must not alter course to mislead or prevent the other from keeping out of the way.

## BEAUFORT WIND SCALE

A yacht which touches the mark must retire immediately unless she corrects her error by sailing completely round the mark leaving it on the required side without touching it, in addition to rounding as required to sail the course. She must keep clear during re-rounding.

If the yacht claims she is wrongfully forced on to the mark, her helm must protest immediately and carry on with the race.

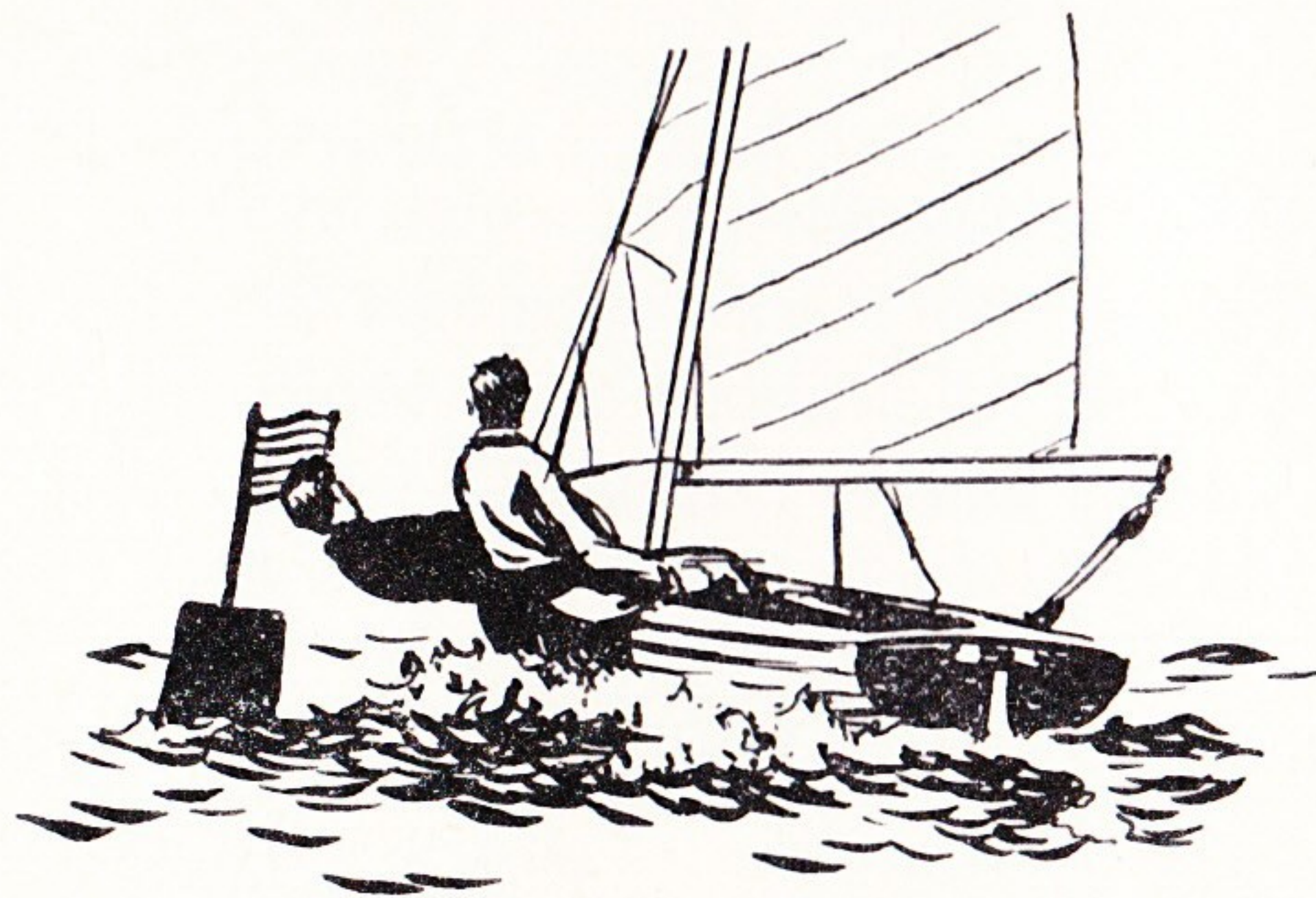

*Fig. 71 A mark can be fouled if the crew sitting outboard touches any part of it*

<i>Force</i>	<i>Wind strength</i>	<i>Speed (knots)</i>	<i>Effect on Open sea</i>	<i>Effect on Shore</i>	<i>Effect on Dinghy</i>
0	Calm	0	Glassy	Smoke rises vertically	Drifting
1	Light air	1-3	Scale-like ripples	Smoke shows wind direction	May be difficult to make way over current — crew sits on lee side.
2	Light breeze	4-6	Small wavelets with glassy crests	Leaves rustle	Wind felt on face — sails fill — crew sits amidships
3	Gentle breeze	7-10	Large wavelets — crests begin to break	Leaves and twigs in constant motion	Helmsman and crew sit inboard on weather side
4	Moderate breeze	11-15	Small waves, with a few white horses	Small branches move — paper blows about, washing on line blows out	Light dinghies may need sitting out
5	Fresh breeze	16-20	Moderate waves, frequent white horses	Small trees sway, washing on line flutters	Sit out most dinghies, ease sheets in gusts — may need to reef
6	Strong breeze	21-26	Large waves, crests white everywhere — some spray	Large branches move	One, probably two, reefs needed
7	Moderate gale	27-32	White foam blown in streaks from breakers	Whole trees in motion	Drop mainsail and bring the dinghy home under jib

## **The Royal Yachting Association**

The R.Y.A. is the national authority for all who boat, whether under sail or power. It has a membership of over 1,500 affiliated clubs and 30,000 individuals. Anyone interested in joining should write to the Secretary, R.Y.A., 5 Buckingham Gate, London, S.W.1.

The annual subscription for full members is 2 guineas per year.

The Association runs a National Proficiency Certificate Scheme, which contains five different Certificates: the Elementary Dayboat, Advanced Dayboat, Coastal, Motor Launch and Powerboat and a National Offshore Sailing Certificate. Details of establishments teaching for these Certificates can be obtained from the Royal Yachting Association.

The National Offshore Sailing Certificate is in the form of a log book which is obtained by individuals, at the price of 10/-, from the Royal Yachting Association and will take them in four separate grades through sufficient syllabi to qualify them as the Master of an Offshore Pleasure Vessel. All the items are to be vouched for by recognised R.Y.A. teaching establishments and the various grades of achievement are also approved by the Royal Yachting Association.

Write now to the Association for details of this Scheme and of all the other services available to you.

Full members of the R.Y.A. are entitled to receive over 30 separate booklets on different subjects entirely free of charge and much other information of special interest to yachtsmen.

# SAILING TERMS

**Amidships** Middle.

**Athwart** Across.

**Backing** Wind shifting anti-clockwise.

**Beam** Measurement across boat at its widest part.

**Belay** To secure a rope.

**Bend** To fasten one thing to another, such as a rope or sail to a spar

**Carry away** Break.

**Check** To slow or stop the boat; to let out a sheet or rope gradually.

**Draught** The underwater depth of the boat. A centre-board boat has only a few inches draught with plate up, two or more feet with plate down.

**Fair wind** When direction of wind is such that it is not necessary to tack.

**Fluky** Unsteady wind.

**Foul** To tangle running gear, also to collide with or get entangled with another boat or object.

**Foul wind** When the wind is ahead.

**Freeboard** Measurement between gunwale and water.

**Full and by** Sailing as close to the wind as possible, with sails well filled.

**Furl** Roll up.

**Go about** To change from one tack to another.

**Goosewing** To run before the wind with the mainsail on one side and the jib boomed out on the other.

**Guy** Rope attached to a spar to control it.

**Gybe Ho!** Helmsman's warning to crew when about to gybe.

**Heave to** Bringing the boat to a standstill by putting it head to wind, backing the jib and easing the mainsheet.

**In Irons** or **in Stays** When the boat lies head to wind and will not turn to either tack.

**Kedge** Small anchor.

**Let Draw** Hauling in a sheet so that the sail catches the wind.

**Let Fly** Letting the sheets go so that the sail spills the wind.

**L.O.A.** Length overall. Measurement of hull from stem to stern.

**Luff** To bring the boat more head to wind. Also the forward edge of a sail.

**L.W.L.** Length water line. Measurement of hull from stem to stern on water line.

**Miss stays** When a boat fails to tack. When this happens the boat usually ends up 'in irons' or 'in stays'.

**Pay off** To turn away from the wind.

**Pinch** To sail too near the wind.

**Ready about** Helmsman's warning to crew when about to tack—followed by 'Lee Ho' or 'Helm alee'.

**Reef** To reduce sail area.

**Reeve** To thread a rope or wire through eyelet or pulley.

**Sheer away** To bear away.

**Slip** To let go.

**Steerage way** Having sufficient headway to enable the boat to be steered.

**Sternway** Moving stern first.

**Strop** Metal or rope band round block or spar.

**Taken aback** To be put about by a sudden change of wind.

**Topping Lift** Rope which takes weight of boom in larger boats when hoisting or lowering sail.

**Unbend** or **Unreeve** Undo.

**Unship** Remove.

**Veering** Wind shifting clockwise.

**Warp** Rope used for anchoring or towing.

**Whisker pole** Spar for booming out jib when running before the wind.

**Yawing** When boat is sailing an unsteady course.



Published by  
E.P. PUBLISHING CO., LTD.

for

**EDUCATIONAL PRODUCTIONS LIMITED**

17 Denbigh Street, London, S.W.1

*Stores Department: Bradford Road, East Ardsley, Wakefield, Yorks.*

*and compiled on the basis of information made available by*

**ROYAL YACHTING ASSOCIATION**

5 Buckingham Gate, London, S.W.1

1st Edition - 1959

2nd Edition - 1965

Revised Edition - 1969

Total copies printed 102,000

**WORLD COPYRIGHT RESERVED**

© *Educational Productions Ltd.*, 1968

7158 0129 5